

Set utility bar - 96681293AA

Utility bar set - 96681293AA

Simbologia

Per una lettura rapida e razionale sono stati impiegati simboli che evidenziano situazioni di massima attenzione, consigli pratici o semplici informazioni. Prestare molta attenzione al significato dei simboli, in quanto la loro funzione è quella di non dovere ripetere concetti tecnici o avvertenze di sicurezza. Sono da considerare, quindi, dei veri e propri "promemoria". Consultare questa pagina ogni volta che sorgessero dubbi sul loro significato.



Attenzione

La non osservanza delle istruzioni riportate può creare una situazione di pericolo e causare gravi lesioni personali e anche la morte.



Importante

Indica la possibilità di arrecare danno al veicolo e/o ai suoi componenti se le istruzioni riportate non vengono eseguite.



Note

Fornisce utili informazioni sull'operazione in corso.

Riferimenti

I particolari evidenziati in grigio e riferimento numerico (Es. ①) rappresentano l'accessorio da installare e gli eventuali componenti di montaggio forniti a set.

I particolari con riferimento alfabetico (Es. (A)) rappresentano i componenti originali presenti sul motoveicolo.

Tutte le indicazioni destro o sinistro si riferiscono al senso di marcia del motociclo.

Avvertenze generali



Attenzione

Le operazioni riportate nelle pagine seguenti devono essere eseguite da un tecnico specializzato o da un'officina autorizzata Ducati.



Attenzione

Le operazioni riportate nelle pagine seguenti se non eseguite a regola d'arte possono pregiudicare la sicurezza del pilota.



Note

Documentazione necessaria per eseguire il montaggio del Set è il Manuale Officina, relativo al modello di moto in vostro possesso.



Note

Nel caso fosse necessaria la sostituzione di un componente del set consultare la tavola ricambi allegata.

Symbols

To allow quick and easy consultation, this manual uses graphic symbols to highlight situations in which maximum care is required, as well as practical advice or information. Pay attention to the meaning of the symbols since they serve to avoid repeating technical concepts or safety warnings throughout the text. The symbols should therefore be seen as real "reminders". Please refer to this page whenever in doubt as to their meaning.



Warning

Failure to comply with these instructions may put you at risk and lead to severe injury or even death.



Important

Failure to comply with these instructions may lead to serious damage to the motorcycle and/or its components.



Notes

It provides useful information about the current operation.

References

The parts highlighted in grey and with a reference number (e.g. ①) represent the accessory to be installed and any assembly components supplied with the set.

The parts with alphabetic reference (e.g. (A)) represent the original components present on the motorcycle.

All left and right indications are referred to the motorcycle direction of travel (forward riding position).

General notes



Warning

The operations listed in the following pages must be carried out by a specialised technician or by a Ducati authorised service centre.



Warning

Carefully perform the operations on the following pages since they might negatively affect rider safety.



Notes

The Workshop Manual specific for your bike model is the documentation required to assemble the set.



Notes

If a set component needs to be replaced, refer to the attached spare parts table.



Warning

Operating, servicing and maintaining a passenger vehicle or off-highway motor vehicle can expose you to chemicals including engine exhaust, carbon monoxide, phthalates, and lead, which are known to the State of California to cause cancer and birth defects or other reproductive harm. To minimize exposure, avoid breathing exhaust, do not idle the engine except as necessary, service your vehicle in a well-ventilated area and wear gloves or wash your hands frequently when servicing your vehicle. For more information go to www.P65Warnings.ca.gov/passenger-vehicle.

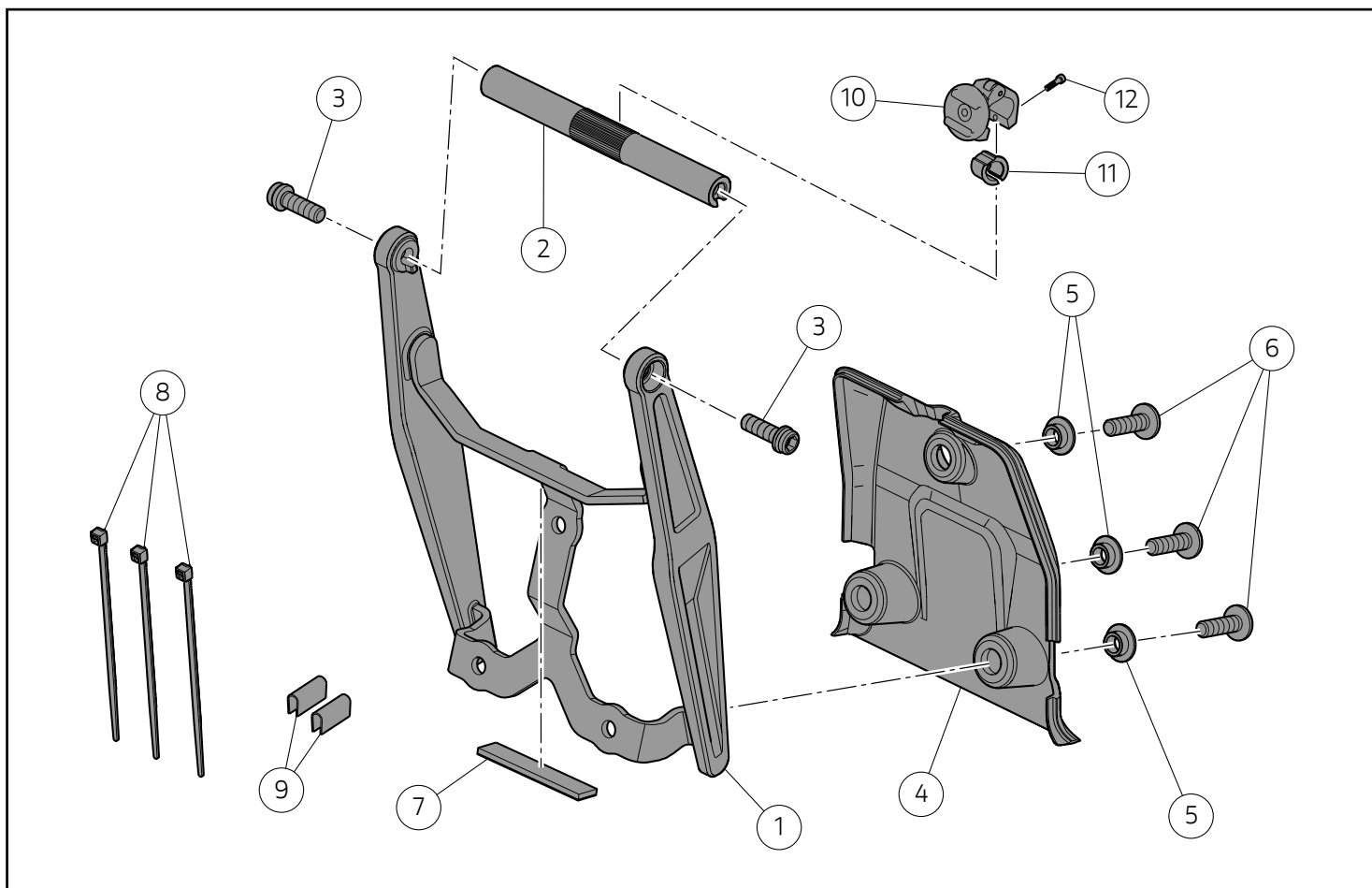

● Importante

I componenti del set possono essere soggetti ad aggiornamenti; consultare il DCS (Dealer Communication System) per avere informazioni sempre aggiornate.

● Important

Set components may be subject to upgrades; refer to the DCS (Dealer Communication System) for updated information.

Pos.	Denominazione	Name
1	Staffa	Bracket
2	Barra utility	Utility bar
3	Vite TCEIF M6x18	TCEIF screw M6x18
4	Cover strumenti	Instrument cover
5	Distanziale con collare	Spacer with collar
6	Vite TBEI M6x20	TBEI screw M6x20
7	Tampone adesivo in gomma	Rubber adhesive buffer
8	Fascetta in nylon	Nylon tie
9	Profilo in gomma	Rubber profile
10	Supporto per smartphone	Smartphone support
11	Anello in gomma	Rubber ring
12	Vite	Screw

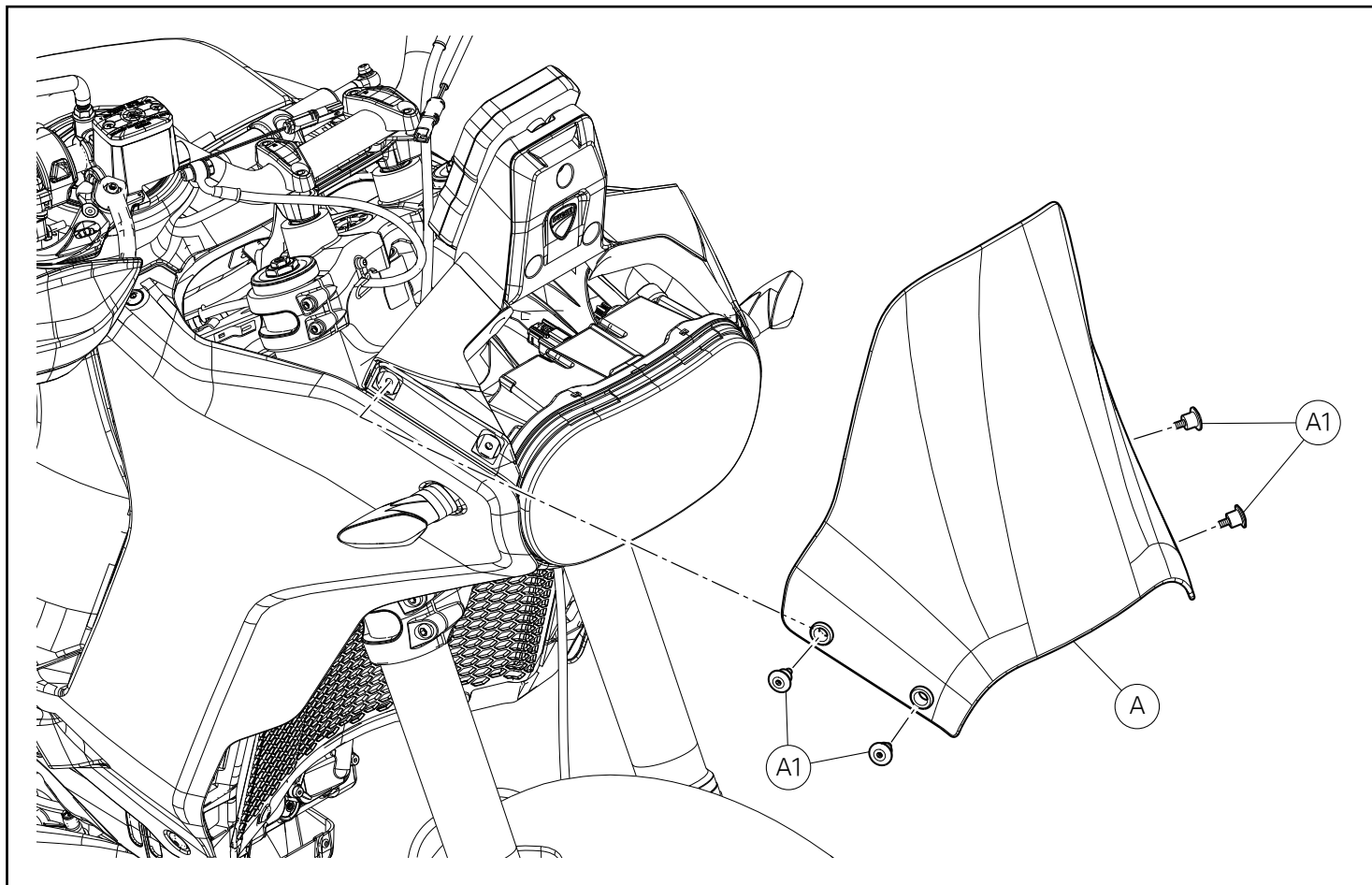

Smontaggio componenti originali

Smontaggio parabrezza

Svitare e rimuovere le n.4 viti (A1) di fissaggio parabrezza (A).
Rimuovere il parabrezza (A).

Removing the original components

Removing the windscreen

Loosen and remove no.4 screws (A1) fastening windscreen (A).
Remove windscreen (A).

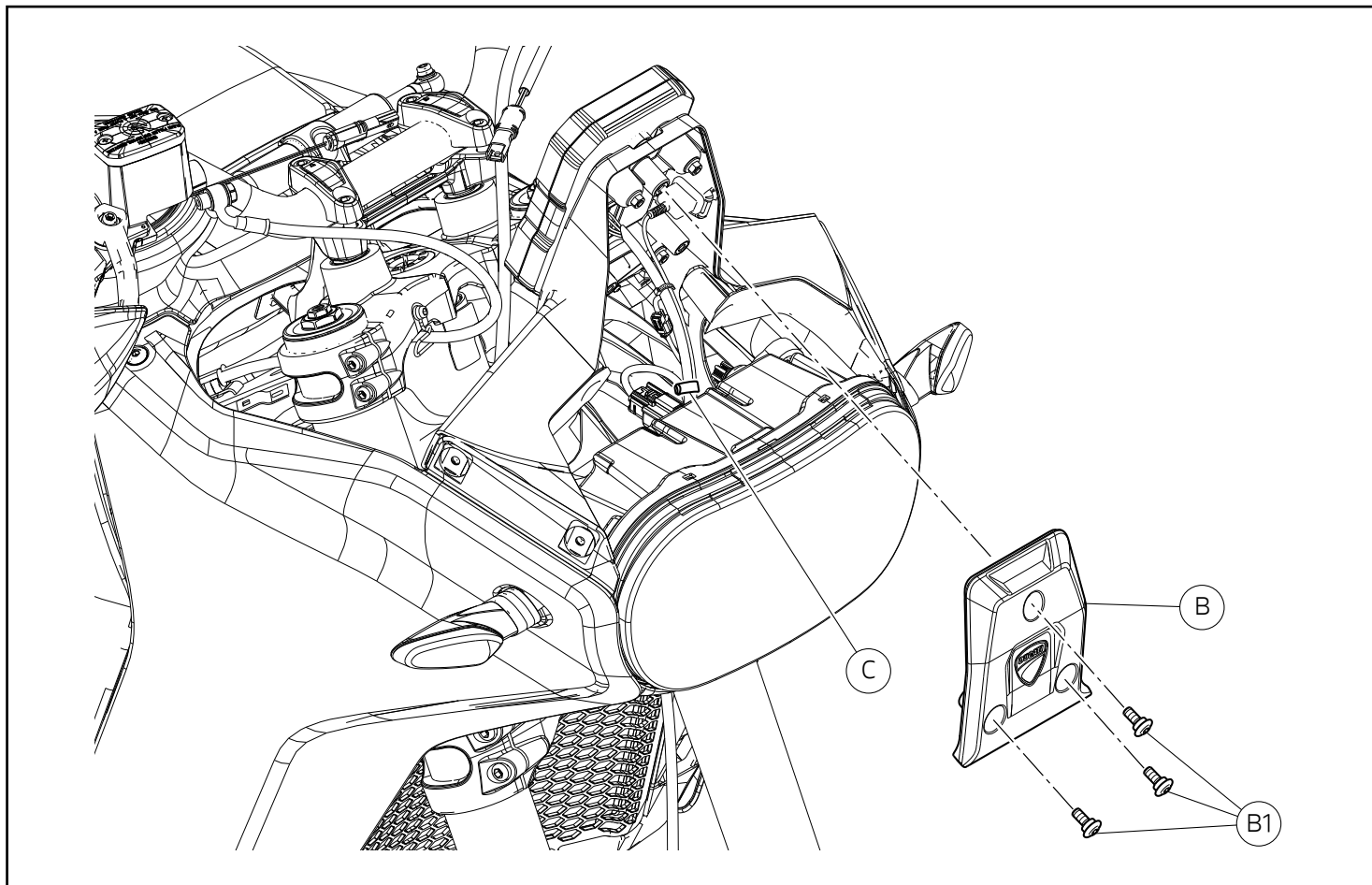

Smontaggio cover telaietto anteriore

Svitare e rimuovere le n.3 viti (B1). Rimuovere il coperchio telaietto anteriore (B). Rimuovere la fascetta in gomma superiore (C).

Removing the front subframe cover

Loosen and remove no.3 screws (B1). Remove the front subframe cover (B). Remove the upper rubber tie (C).

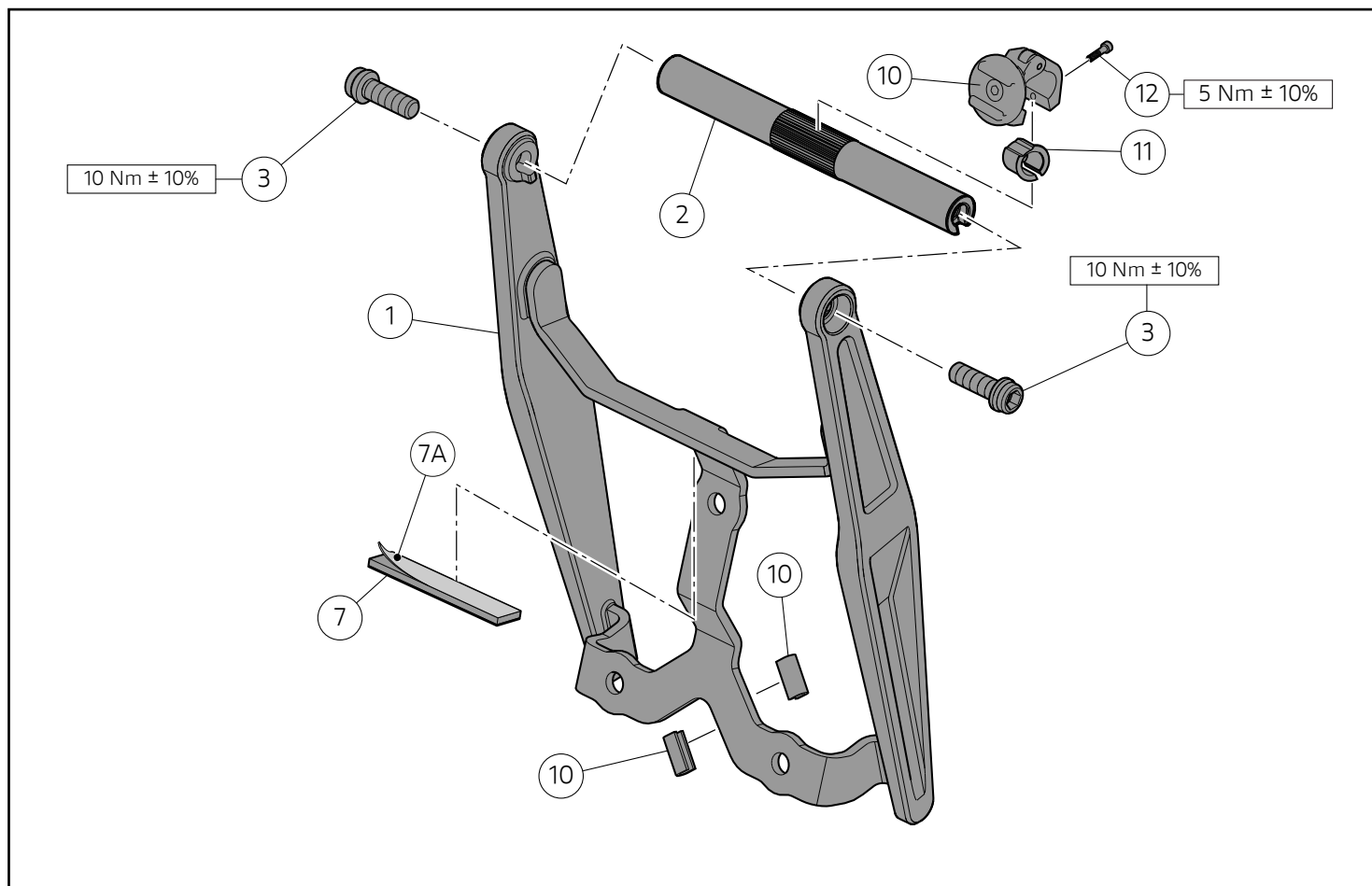

Montaggio componenti set

● Importante

Verificare, prima del montaggio, che tutti i componenti risultino puliti e in perfetto stato. Adottare tutte le precauzioni necessarie per evitare di danneggiare qualsiasi parte nella quale ci si trova ad operare.

Premontaggio staffa

Rimuovere la pellicola (7A) e applicare il tampone adesivo (7) alla staffa (1) come mostrato in figura. Applicare LOCTITE 480 sui n.2 profili in gomma (10) e incollarli alla staffa supporto navigatore (1). Posizionare la barra utility (2) sulla staffa (1). Impuntare le n.2 viti (3). Serrare le n.2 viti (3) alla coppia indicata.

Montaggio supporto smartphone

Infilare l'anello in gomma (17) e posizionare il supporto per smartphone (16). Impuntare la vite (18). Serrare la vite (18) alla coppia indicata.

Assembling the set components

● Important

Before assembly, make sure that all parts are clean and in perfect conditions. Take all the necessary measures to avoid damaging any part you are working on.

Pre-assembling the bracket

Remove the film (7A) and apply the adhesive pad (7) on the bracket (1) as shown in the figure. Apply LOCTITE 480 on the no.2 rubber profiles (10) and glue them to the navigator support bracket (1). Position the utility bar (2) on the bracket (1). Start no.2 screws (3). Tighten no.2 screws (3) to the specified torque.

Assembling the smartphone support

Fit rubber ring (17) and position smartphone support (16). Start screw (18). Tighten screw (18) to the specified torque.

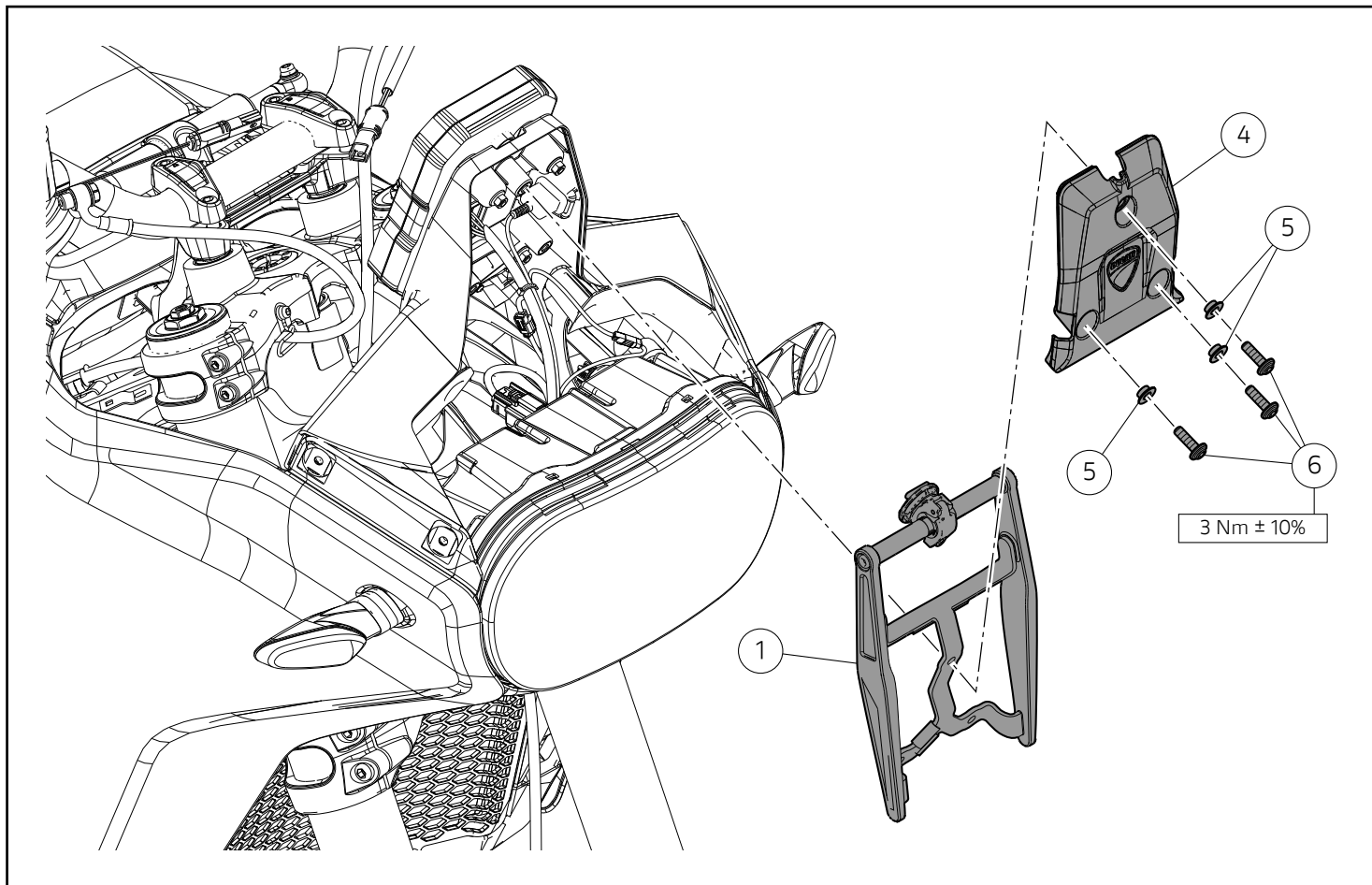

Montaggio staffa

Posizionare la staffa (1) sul motoveicolo. Posizionare la cover strumenti (4) sulla staffa (1). Inserire i n.3 distanziali (5) nella cover strumenti (4), orientandoli come mostrato in figura. Impuntare le n.3 viti (6). Serrare le n.3 viti (6) alla coppia indicata.

Installing the bracket

Position the bracket (1) on the motorcycle. Position the instrument cover (4) on the bracket (1). Fit the no.3 spacers (5) in the instrument cover (4), aiming them as shown in the figure. Start no.3 screws (6). Tighten no.3 screws (6) to the specified torque.

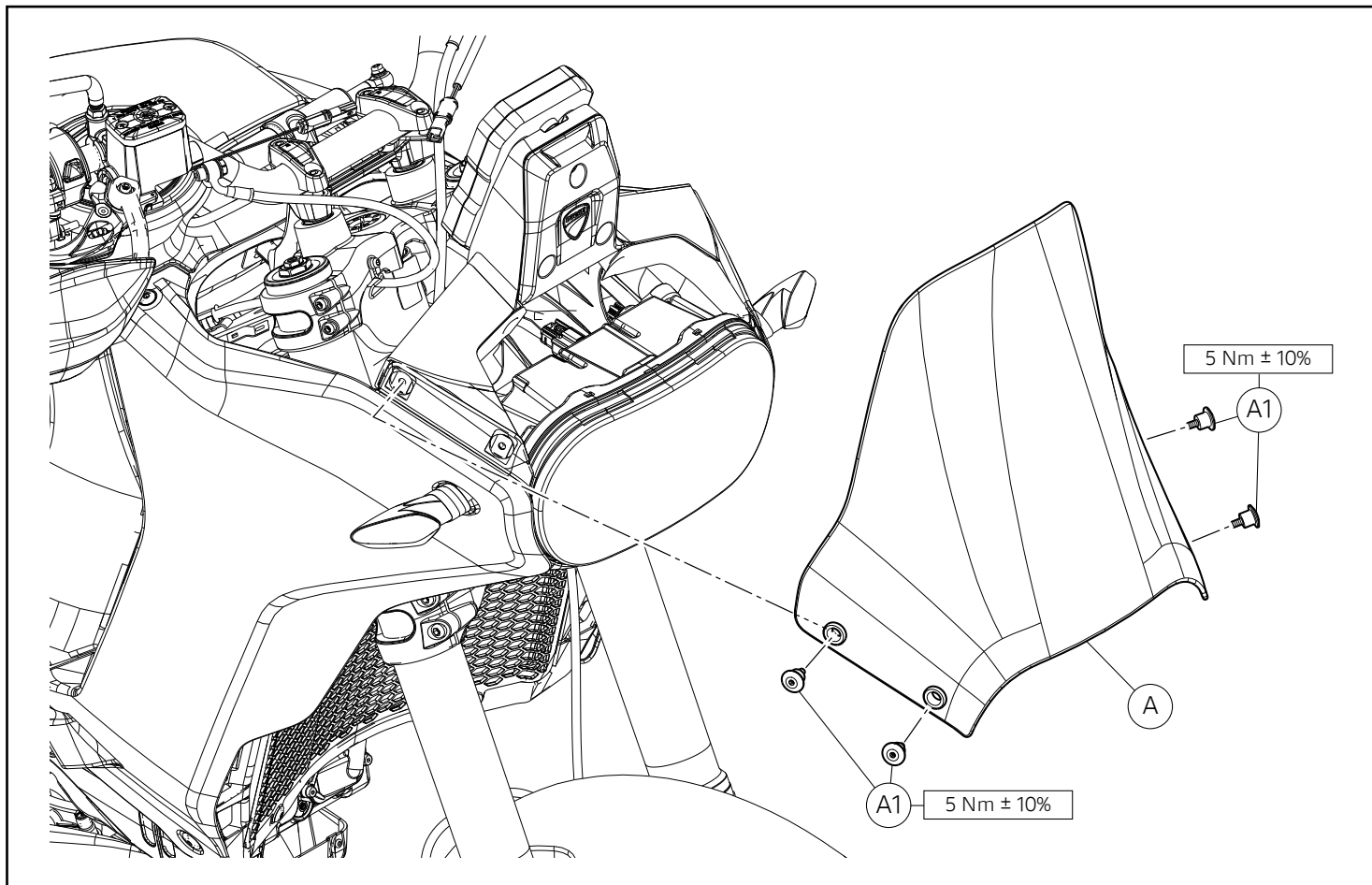

Montaggio parabrezza

Collocare il parabrezza (A) nella sua posizione originale. Impuntare le n.4 viti originali (A1). Serrare le n.4 viti (A1) alla coppia indicata.

Windscreen assembly

Place the windscreen (A) in its original position. Start no.4 original screws (A1). Tighten no.4 screws (A1) to the specified torque.

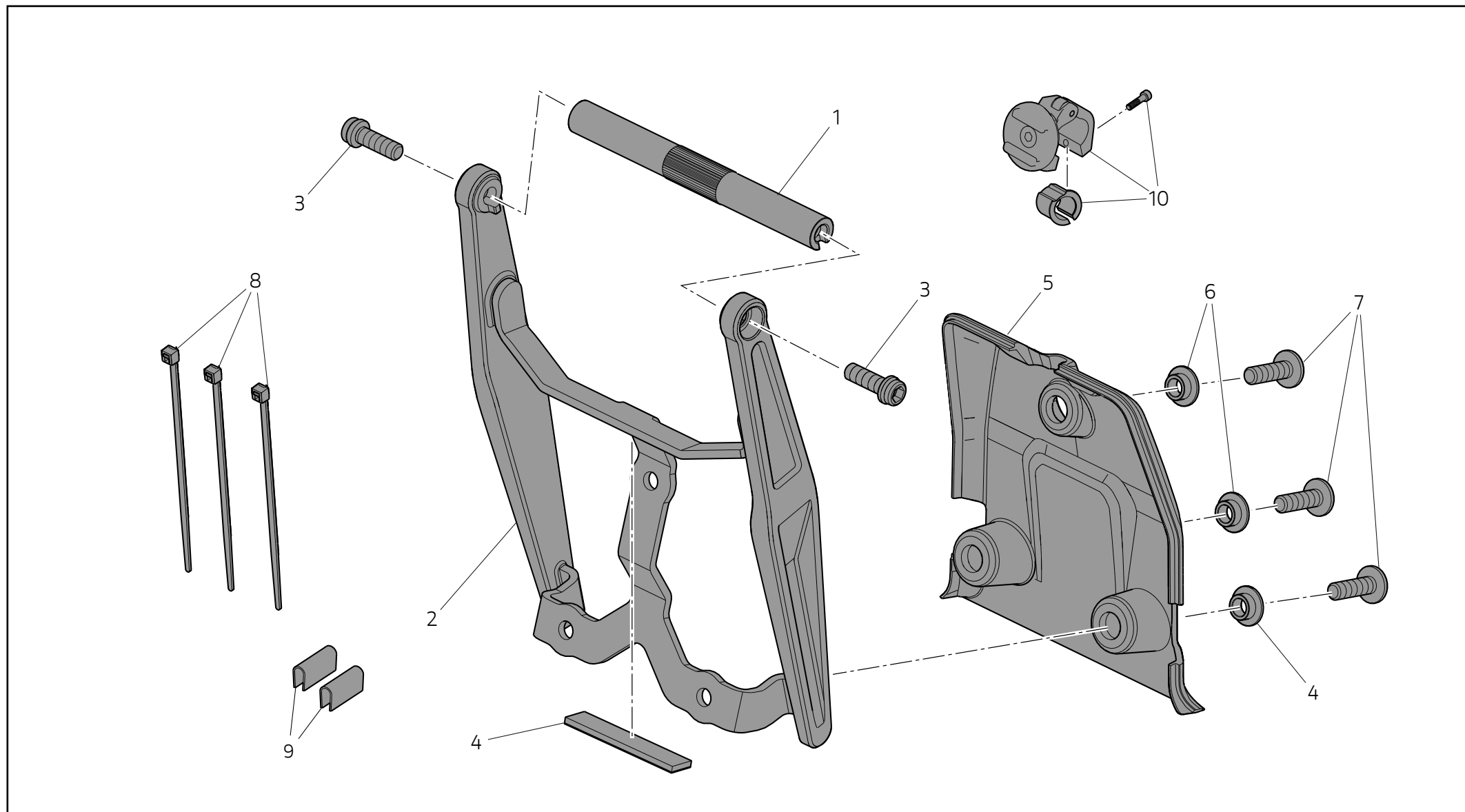

Pos.	Cod.	Nome	Name	Nom	Name	Nome	名称	Nombre	名称	Q.ty
1	97312481AA	Barra utility	Utility bar	Barre utilitaire	Utility-Leiste	Barra utility	实用杠杆	Barra utility	ユーティリティバー	1
2	97312451A	Staffa	Bracket	Bride	Bügel	Braçadeira	托架	Sostén	ブラケット	1
3	77110401B	Vite TCEIF M6x18	TCEIF screw M6x18	Vis TCHCF M6x18	Zylinderschraube mit Innensechskant und Flansch M6x18	Parafuso de cabeça cilíndrica flangeada com sextavado interno M6x18	TCEIF 螺钉 M6x18	Tornillo TCEIF M6x18	スクリュー TCEIF M6x18	2
4	78811521A	Tampone adesivo	Adhesive pad	Tampon autocollant	Klebepad	Tampão adesivo	粘贴式缓冲垫	Tope adesivo	シールパッド	1
5	96610901A	Cover strumenti	Instrument cover	Cache instrumentation	Cover Instrumente	Cobertura dos instrumentos	仪表罩	Cover instrumentos	インストルメントパネルカバー	1
6	71610213AA	Distanziale con collare	Spacer with collar	Entretoise à collerette	Distanzstück mit Bund	Espaçador com colar	带环垫片	Separador con collar	カラー付きスペーサー	3
7	77244353BA	Vite TBEI M6x20	TBEI screw M6x20	Vis TBHC M6x20	Linsenkopfschraube mit Innensechskant M6x20	Parafuso de cabeça abaulada com sextavado interno M6x20	TBEI 螺钉 M6x20	Tornillo TBEI M6x20	スクリュー TBEI M6x20	3
8	74140381A	Fascetta in nylon	Nylon tie	Collier serre-flex en nylon	Nylonschelle	Braçadeira de nylon	尼龙扎带	Abrazadera de nylon	ナイロンクランプ	3
9	76414241A	Profilo in gomma	Rubber profile	Profil en caoutchouc	Gummiprofil	Perfil de borracha	橡胶轮廓	Perfil de goma	ラバー製の縁	2
10	96610911A	Supporto smartphone	Smartphone support	Support smartphone	Smartphone-Halter	Suporte para smartphone	智能手机支架	Soporte smartphone	スマートフォンサポート	1