

**Set cover monoposto** - 97180952AA (Rosso) - 97180952AB (Nero) - 97180952AC (Grigio)

**Single-seater cover set** - 97180952AA (Red) - 97180952AB (Black) - 97180952AC (Grey)

## Simbologia

Per una lettura rapida e razionale sono stati impiegati simboli che evidenziano situazioni di massima attenzione, consigli pratici o semplici informazioni. Prestare molta attenzione al significato dei simboli, in quanto la loro funzione è quella di non dovere ripetere concetti tecnici o avvertenze di sicurezza. Sono da considerare, quindi, dei veri e propri "promemoria". Consultare questa pagina ogni volta che sorgessero dubbi sul loro significato.



### Attenzione

La non osservanza delle istruzioni riportate può creare una situazione di pericolo e causare gravi lesioni personali e anche la morte.



### Importante

Indica la possibilità di arrecare danno al veicolo e/o ai suoi componenti se le istruzioni riportate non vengono eseguite.



### Note

Fornisce utili informazioni sull'operazione in corso.

## Riferimenti

I particolari evidenziati in grigio e riferimento numerico (Es. ①) rappresentano l'accessorio da installare e gli eventuali componenti di montaggio forniti a set.

I particolari con riferimento alfabetico (Es. Ⓐ) rappresentano i componenti originali presenti sul motoveicolo.

Tutte le indicazioni destro o sinistro si riferiscono al senso di marcia del motociclo.

## Avvertenze generali



### Attenzione

Le operazioni riportate nelle pagine seguenti devono essere eseguite da un tecnico specializzato o da un'officina autorizzata Ducati.



### Attenzione

Le operazioni riportate nelle pagine seguenti se non eseguite a regola d'arte possono pregiudicare la sicurezza del pilota.



### Note

Documentazione necessaria per eseguire il montaggio del Set è il Manuale Officina, relativo al modello di moto in vostro possesso.



### Note

Nel caso fosse necessaria la sostituzione di un componente del set consultare la tavola ricambi allegata.

## Symbols

To allow quick and easy consultation, this manual uses graphic symbols to highlight situations in which maximum care is required, as well as practical advice or information. Pay attention to the meaning of the symbols since they serve to avoid repeating technical concepts or safety warnings throughout the text. The symbols should therefore be seen as real "reminders". Please refer to this page whenever in doubt as to their meaning.



### Warning

Failure to comply with these instructions may put you at risk and lead to severe injury or even death.



### Important

Failure to comply with these instructions may lead to serious damage to the motorcycle and/or its components.



### Notes

It provides useful information about the current operation.

## References

The parts highlighted in grey and with a reference number (e.g. ①) represent the accessory to be installed and any assembly components supplied with the set.

The parts with alphabetic reference (e.g. Ⓐ) represent the original components present on the motorcycle.

All left and right indications are referred to the motorcycle direction of travel (forward riding position).

## General notes



### Warning

The operations listed in the following pages must be carried out by a specialised technician or by a Ducati authorised service centre.



### Warning

Carefully perform the operations on the following pages since they might negatively affect rider safety.



### Notes

The Workshop Manual specific for your bike model is the documentation required to assemble the set.



### Notes

If a set component needs to be replaced, refer to the attached spare parts table.



### Warning

Operating, servicing and maintaining a passenger vehicle or off-highway motor vehicle can expose you to chemicals including engine exhaust, carbon monoxide, phthalates, and lead, which are known to the State of California to cause cancer and birth defects or other reproductive harm. To minimize exposure, avoid breathing exhaust, do not idle the engine except as necessary, service your vehicle in a well-ventilated area and wear gloves or wash your hands frequently when servicing your vehicle. For more information go to [www.P65Warnings.ca.gov/passenger-vehicle](http://www.P65Warnings.ca.gov/passenger-vehicle).

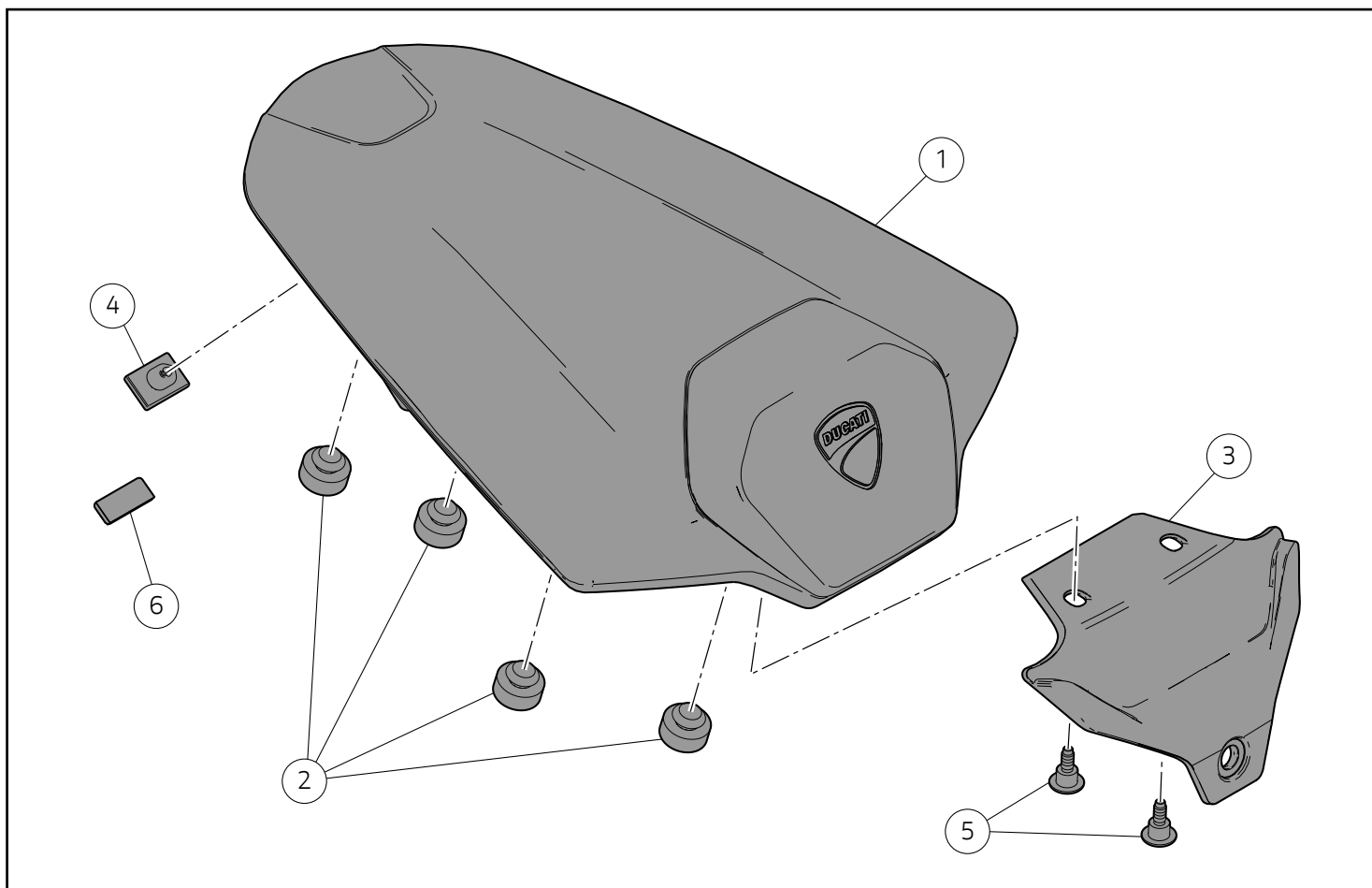

### Importante

I componenti del set possono essere soggetti ad aggiornamenti; consultare il DCS (Dealer Communication System) per avere informazioni sempre aggiornate.

### Important

Set components may be subject to upgrades; refer to the DCS (Dealer Communication System) for updated information.

Pos.	Denominazione	Name
1	Cover monoposto	Single-seater cover
2	Tampone	Buffer
3	Staffa fissaggio	Fixing bracket
4	Tampone	Buffer
5	Vite con collare M5x10.5	Screw with collar M5x10.5
6	Tampone adesivo	Adhesive pad

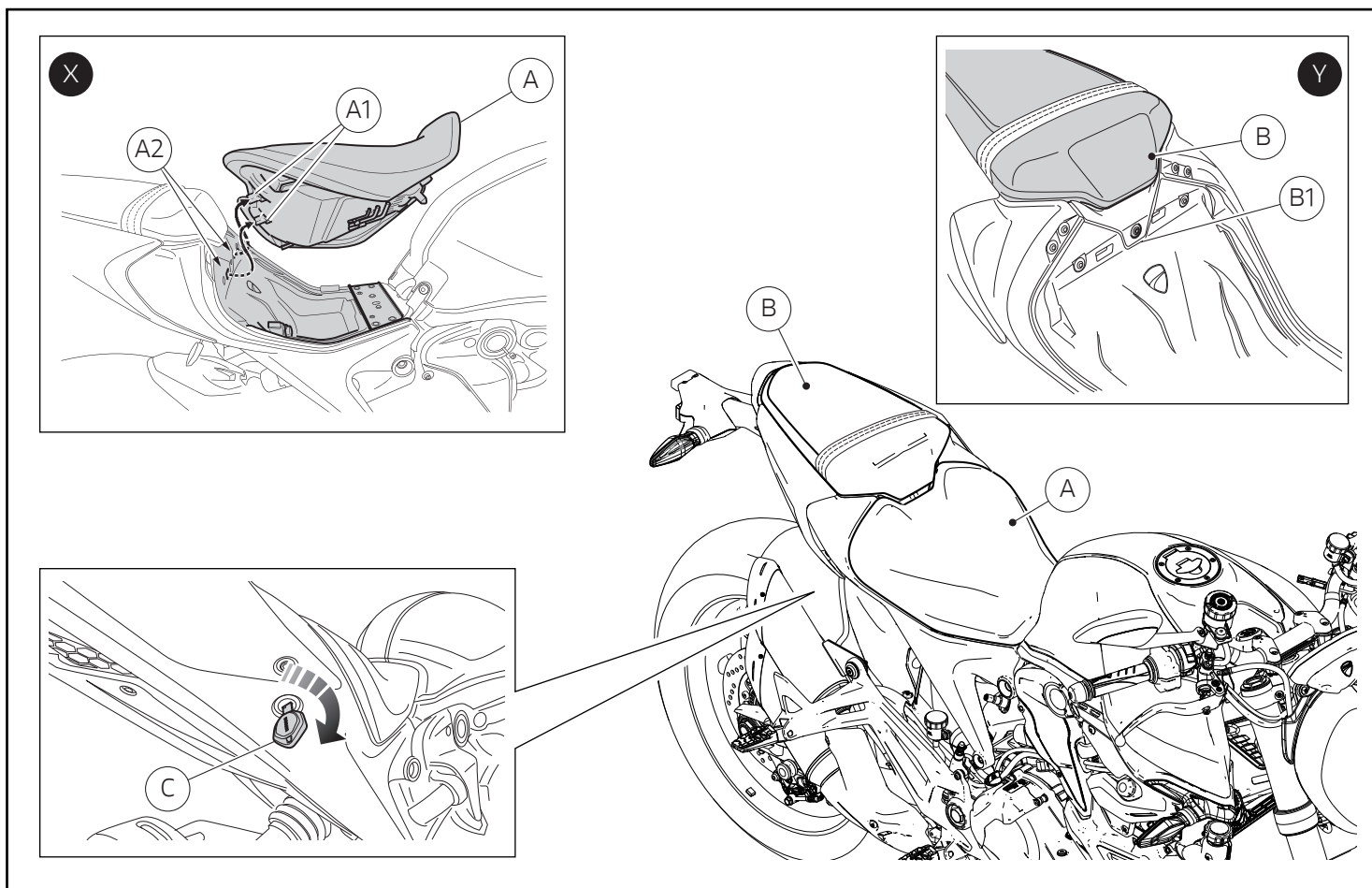

## Smontaggio componenti originali

### Smontaggio sella pilota

Introdurre la chiave (C) nella serratura e ruotarla in senso orario. Sollevare la sella pilota (A) dal lato anteriore, sfilando le alette posteriori (A1) dalle sedi (A2).

### Smontaggio sella passeggero

Svitare la vite centrale (B1) e sfilare anteriormente la sella passeggero (B).

## Removing the original components

### Removing the rider seat

Insert the key (C) in the lock and turn it clockwise. Lift the rider's seat (A) from the front, pulling the rear flaps (A1) out of their seats (A2).

### Removing the passenger seat

Loosen the central screw (B1) and remove the passenger seat (B) from the front.

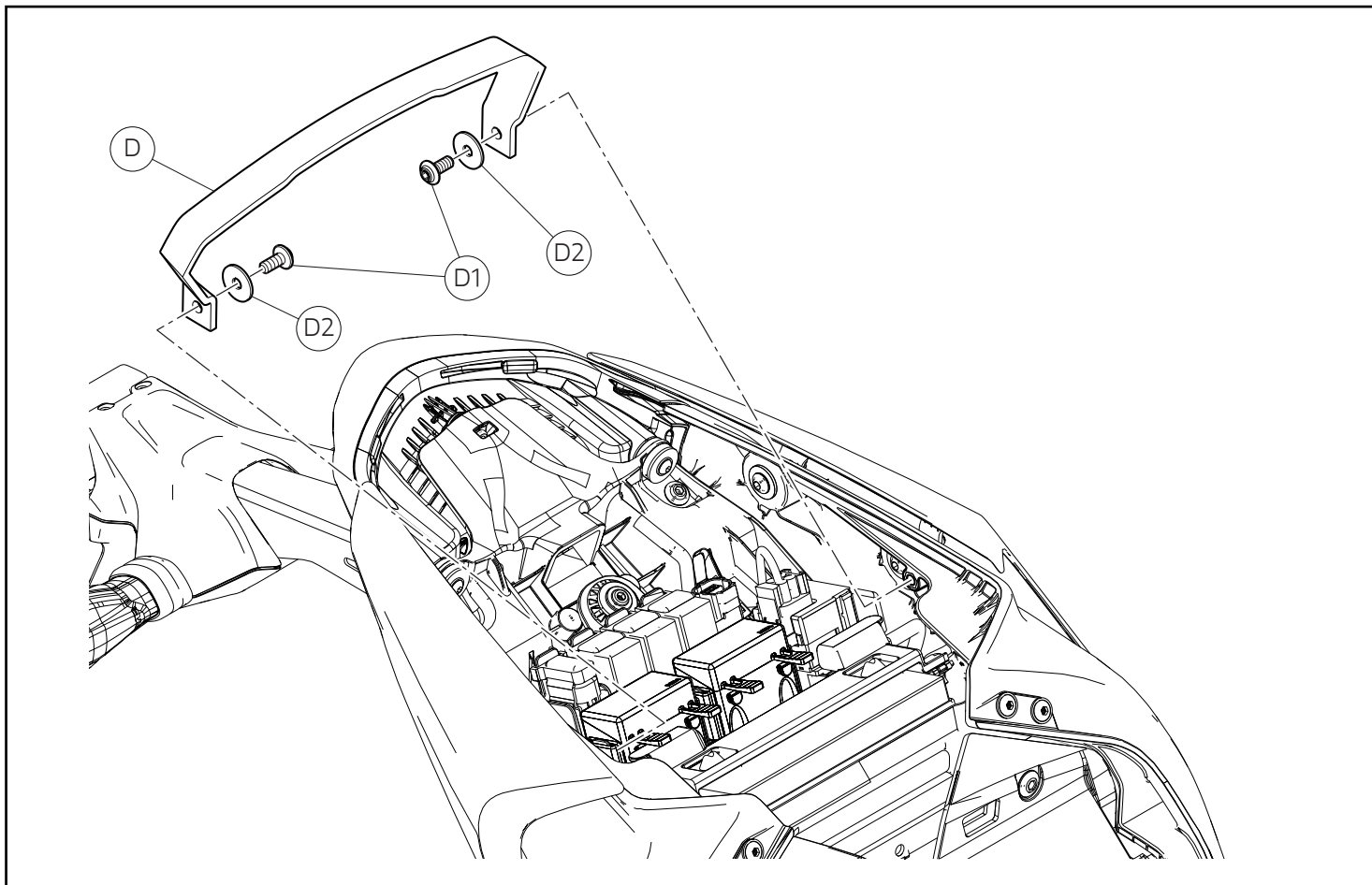

### Rimozione cinghietto

Svitare le n.2 viti (D1) e rimuoverle complete delle n.2 rondelle (D2).  
Rimuovere il cinghietto (D).

### Removing the strap

Loosen no.2 screws (D1) and remove them together with no.2 washers (D2). Remove the strap (D).

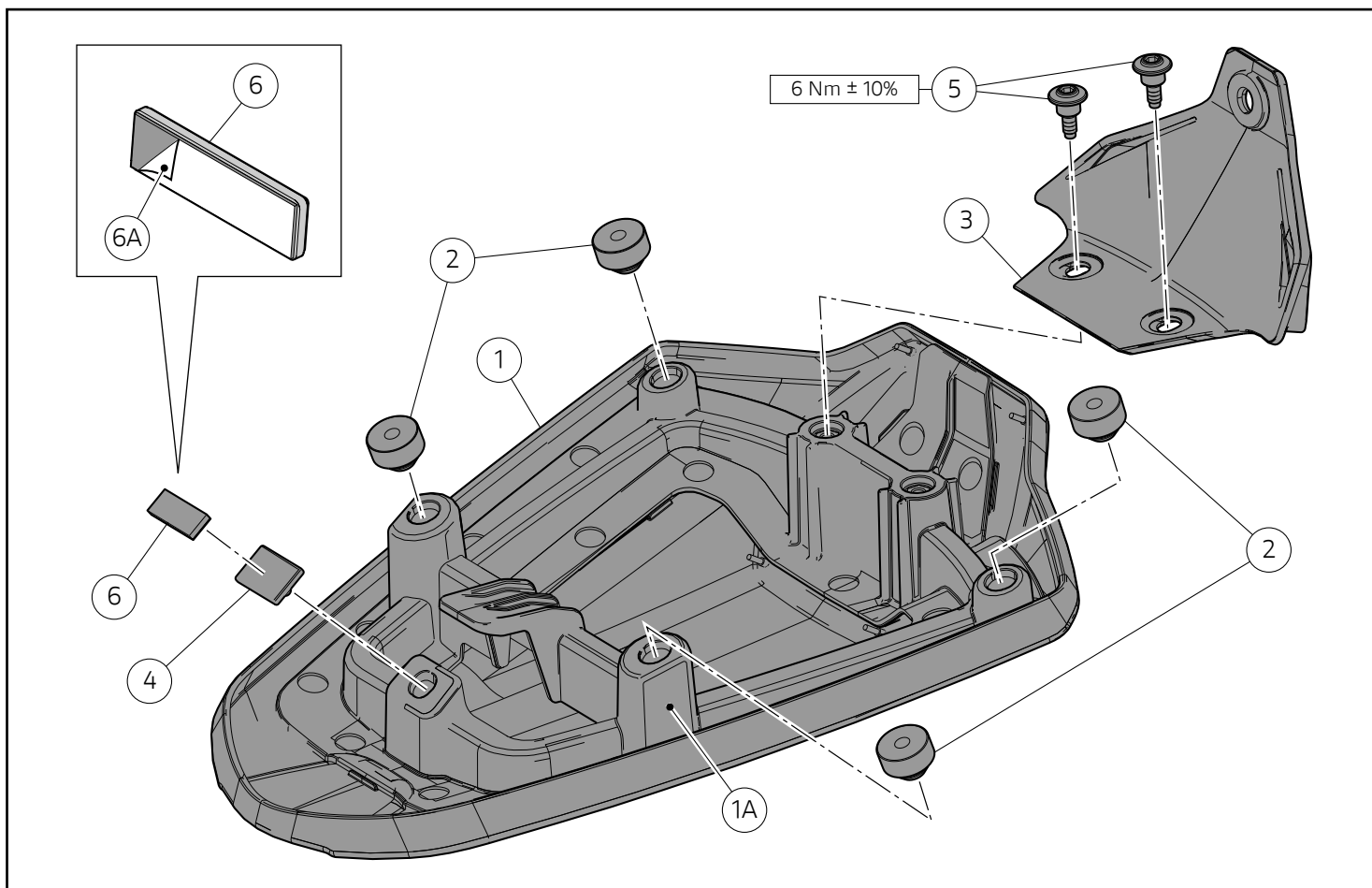

## Montaggio componenti set

### ● Importante

Verificare, prima del montaggio, che tutti i componenti risultino puliti e in perfetto stato. Adottare tutte le precauzioni necessarie per evitare di danneggiare qualsiasi parte nella quale ci si trova ad operare.

### Premontaggio cover monoposto

Operare sulla parte inferiore della cover monoposto (1). Premontare i n.4 tamponi in gomma (2) nelle relative sedi del fondo (1A) della cover monoposto (1), orientandoli come mostrato in figura.

### 👁 Note

In caso di difficoltà durante il montaggio dei tamponi in gomma (2), è raccomandato l'utilizzo di lubrificante per gomma, da applicare su i tamponi stessi.

Calzare il gommino (4) nella relativa sede. Rimuovere la pellicola protettiva (6A) della parte adesiva del gommino (6). Applicare il gommino adesivo (6) sulla superficie del gommino (4) appena inserito nella relativa sede del fondo (1A) della cover monoposto (1), come mostrato in figura.

Posizionare la staffa (3) sulla parte anteriore della cover monoposto (1) ed impuntare le n.2 viti (5). Serrare le n.2 viti (5) alla coppia indicata.

## Assembling the set components

### ● Important

Before assembly, make sure that all parts are clean and in perfect conditions. Take all the necessary measures to avoid damaging any part you are working on.

### Single-seater cover pre-assembly

Work on the lower side of the single-seater cover (1). Pre-fit no.4 rubber pads (2) in the relevant seats of single-seater cover (1) bottom (1A), positioning them as shown in the figure.

### 👁 Notes

If rubber blocks (2) prove difficult to fit, the application of rubber lubricant is recommended.

Fit rubber block (4) in the relevant seat. Remove the protective film (6A) of the adhesive side of the rubber block (6). Apply the adhesive rubber block (6) on the surface of the rubber block (4) just fitted in the relevant seat of single-seater cover (1) bottom (1A), as shown in the figure.

Position the bracket (3) on the front side of the single-seater cover (1) and start no.2 screws (5). Tighten no.2 screws (5) to the specified torque.

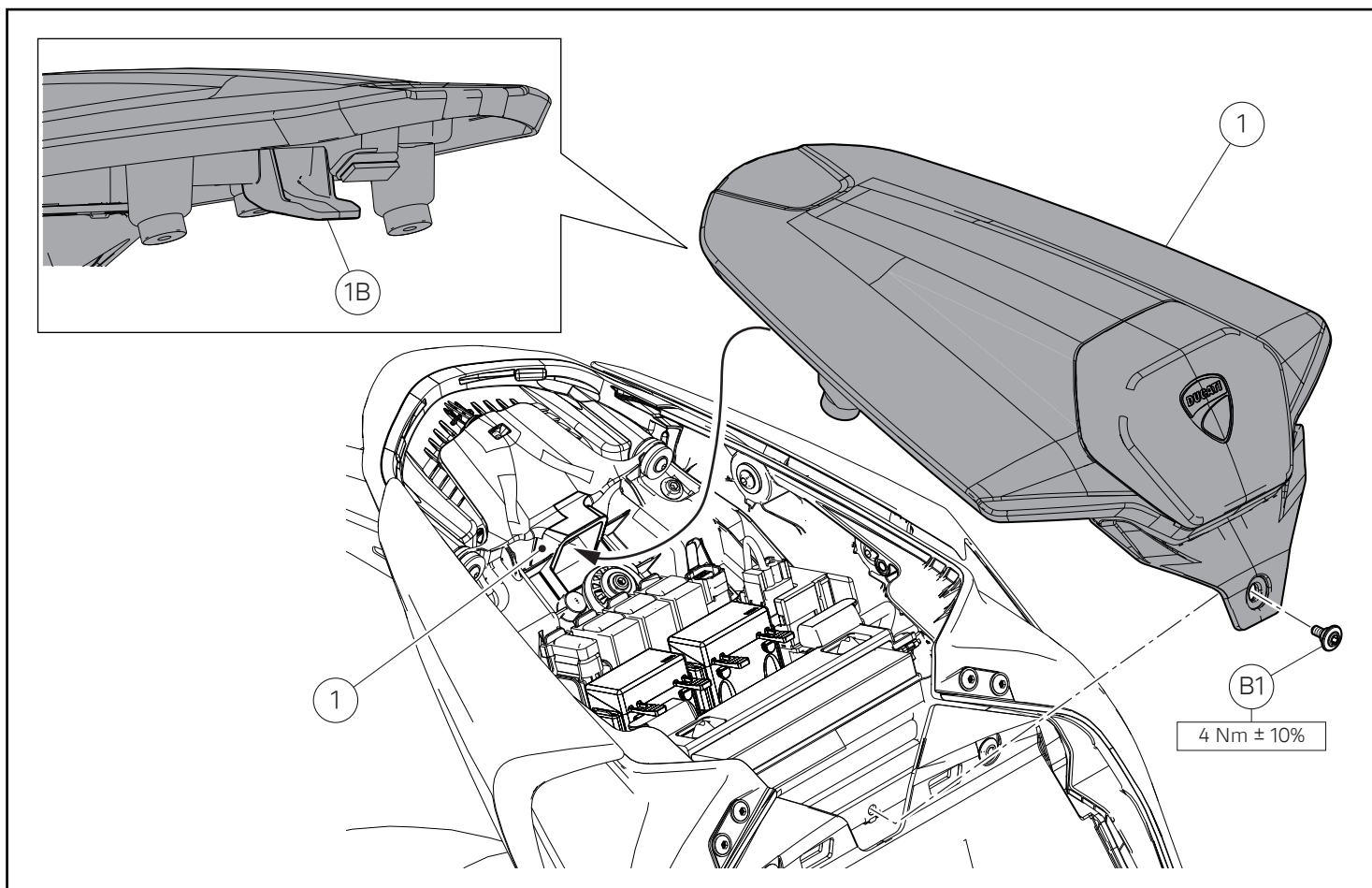

### Montaggio cover monoposto

Posizionare la cover monoposto (1) assicurandosi che l'aletta (1B) si inserisca nella sede (B2). Verificare il corretto posizionamento e allineamento della cover monoposto (1). Impuntare la vite originale (B1). Serrare la vite (B1) alla coppia indicata.

### Assembling the single-seater cover

Position the single-seater cover (1), making sure to insert flap (1B) in seat (B2). Check that the single-seater cover (1) is correctly positioned and aligned. Start the original screw (B1). Tighten the screw (B1) to the specified torque.

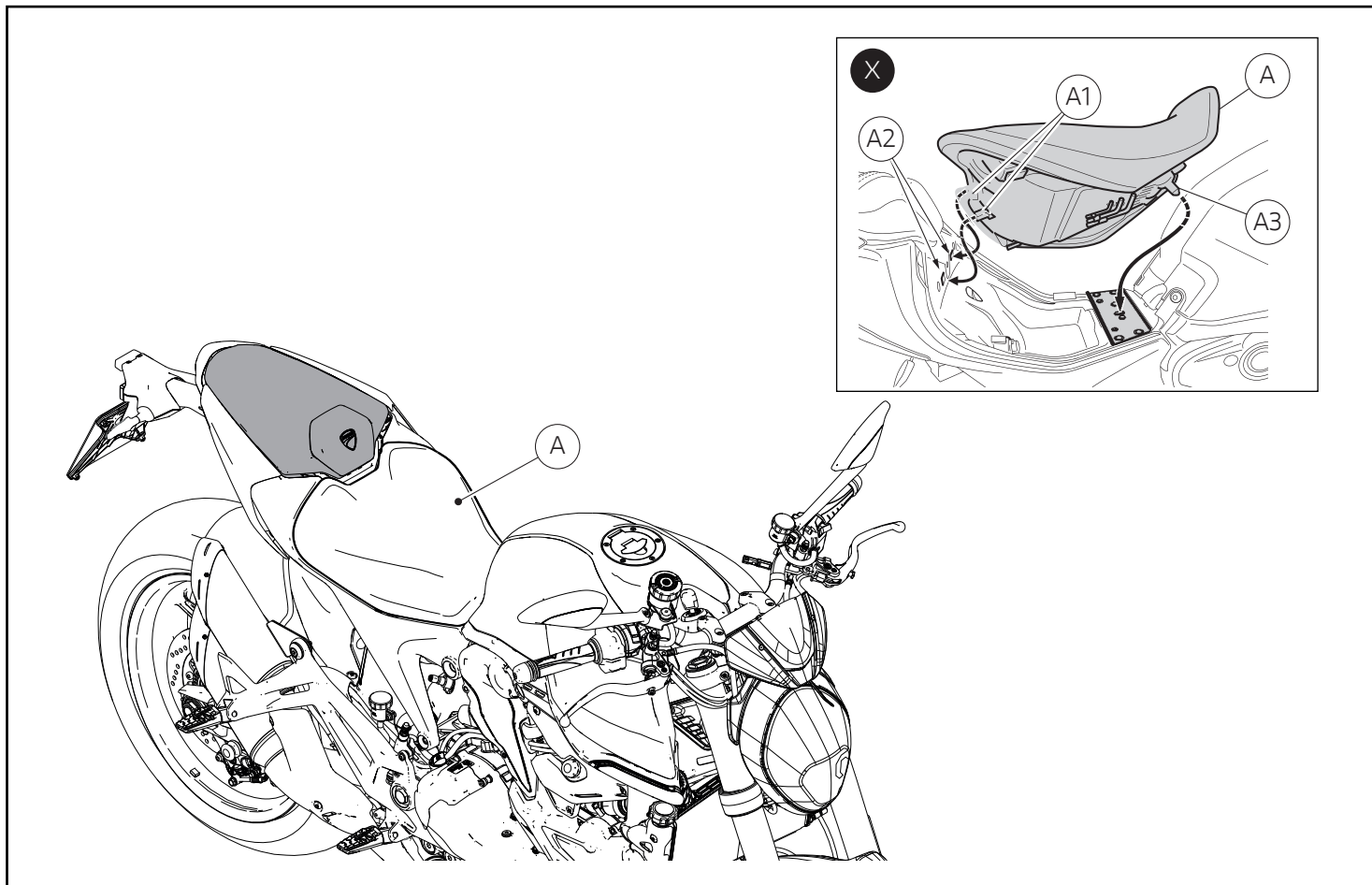

### Rimontaggio sella pilota

Inserire le alette (A1), poste sull'estremità posteriore del fondo sella, nelle sedi (A2) sul telaietto posteriore. Inserire il fissaggio centrale (A3) spingendo sopra di esso: spingere sull'estremità anteriore della sella (A), fino ad udire lo scatto del chiavistello della serratura. Assicurarsi che la sella sia saldamente fissata al telaio e rimuovere la chiave dalla serratura.

### Re-assembling the rider seat

Insert the flaps (A1), located on the rear end of the seat bottom, into the seats (A2) on the rear subframe. Insert the central fastener (A3) by pushing on it: push on the front end of the seat (A) until you hear the lock latch click into place. Make sure that the seat is firmly secured to the frame and remove the key from the lock.





Set cover monoposto / Single-seater cover set / Jeu cache monoplace / Set Monoposto-Abdeckung / Conjunto cobertura monoposto / 单人鞍座罩套装 / Set cover monoplaza / モノポストカバーセット - 97180952AA (Red) - 97180952AB (Black) - 97180952AC (Grey)

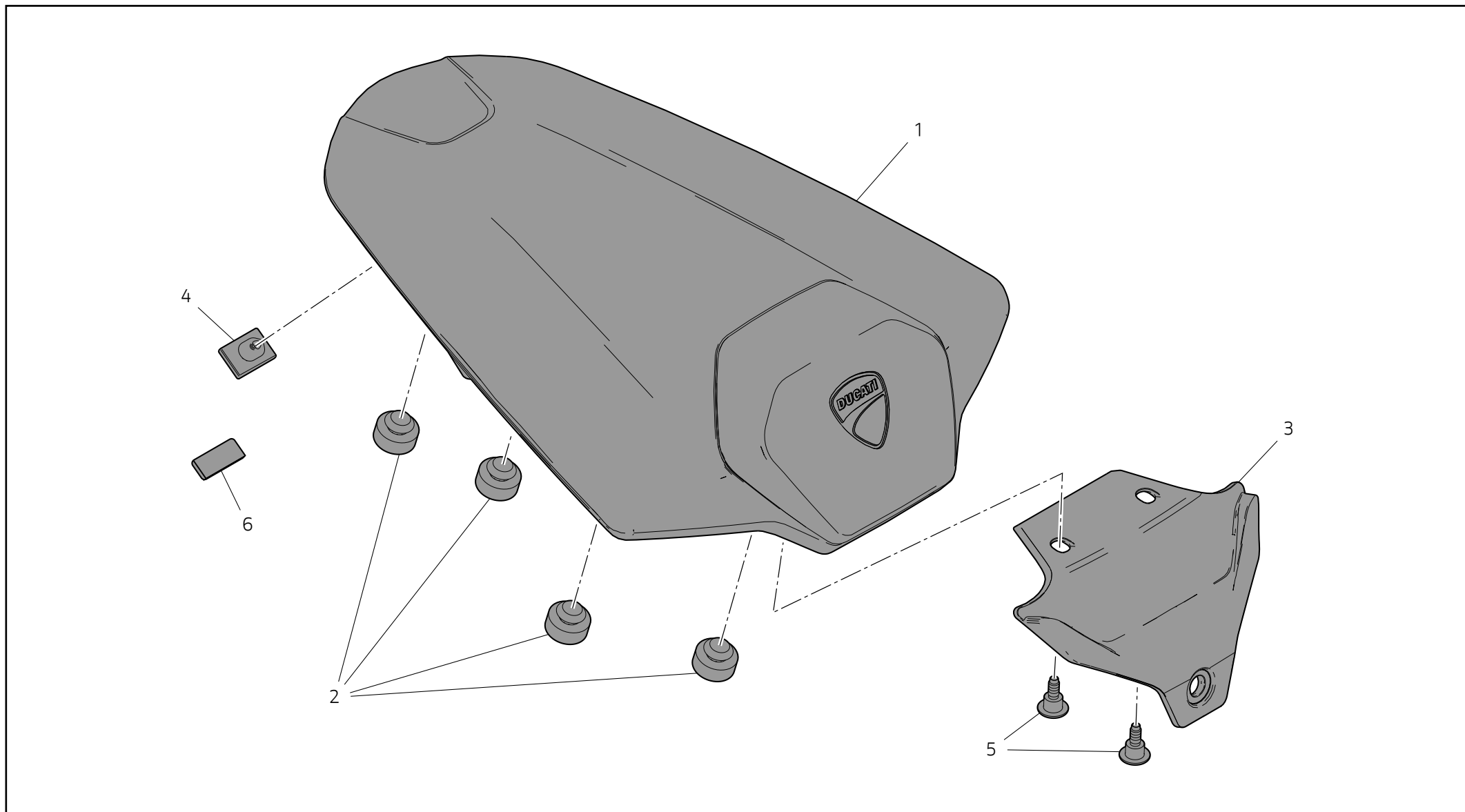

Pos.	Cod.	Nome	Name	Nom	Name	Nome	名称	Nombre	名称	Q.ty
1	24727071AA	Cover monoposto	Single-seater cover	Cache monoplace	Monoposto-Abdeckung	Cobertura monoposto	单人鞍座罩	Cover monoplaaza	モノポストカバー	1
2	86612221A	Tampone	Buffer	Tampon	Puffer	Tampão	缓冲器	Tapón	パッド	4
3	8301L111A	Staffa fissaggio	Fixing bracket	Bride de fixation	Befestigungsbügel	Braçadeira de fixação	固定托架	Sostén fijación	固定用ブラケット	1
4	86610301B	Tampone	Buffer	Tampon	Puffer	Tampão	缓冲器	Tapón	パッド	1
5	77210841BA	Vite con collare M5x10.5	Screw with collar M5x10.5	Vis à collette M5x10.5	Schraube mit Bundstück M5x10.5	Parafuso com colar M5x10.5	带环螺钉 M5x10.5	Tornillo con collar M5x10.5	カラー付きスクリュー M5x10.5	2
6	78812011A	Tampone adesivo	Adhesive pad	Tampon autocollant	Klebepad	Tampão adesivo	粘贴式缓冲垫	Tope adhesivo	シールパッド	1