

Kit puntale motore - 97180961AA (Rosso) - 97180961AB (Nero) - 97180961AC (Grigio)

Engine belly fairing kit - 97180961AA (Red) - 97180961AB (Black) - 97180961AC (Grey)

Simbologia

Per una lettura rapida e razionale sono stati impiegati simboli che evidenziano situazioni di massima attenzione, consigli pratici o semplici informazioni. Prestare molta attenzione al significato dei simboli, in quanto la loro funzione è quella di non dovere ripetere concetti tecnici o avvertenze di sicurezza. Sono da considerare, quindi, dei veri e propri "promemoria". Consultare questa pagina ogni volta che sorgessero dubbi sul loro significato.



Attenzione

La non osservanza delle istruzioni riportate può creare una situazione di pericolo e causare gravi lesioni personali e anche la morte.



Importante

Indica la possibilità di arrecare danno al veicolo e/o ai suoi componenti se le istruzioni riportate non vengono eseguite.



Note

Fornisce utili informazioni sull'operazione in corso.

Riferimenti

I particolari evidenziati in grigio e riferimento numerico (Es. ①) rappresentano l'accessorio da installare e gli eventuali componenti di montaggio forniti a kit.

I particolari con riferimento alfabetico (Es. Ⓐ) rappresentano i componenti originali presenti sul motoveicolo.

Tutte le indicazioni destro o sinistro si riferiscono al senso di marcia del motociclo.

Avvertenze generali



Attenzione

Le operazioni riportate nelle pagine seguenti devono essere eseguite da un tecnico specializzato o da un'officina autorizzata Ducati.



Attenzione

Le operazioni riportate nelle pagine seguenti se non eseguite a regola d'arte possono pregiudicare la sicurezza del pilota.



Note

Documentazione necessaria per eseguire il montaggio del Kit è il Manuale Officina, relativo al modello di moto in vostro possesso.



Note

Nel caso fosse necessaria la sostituzione di un componente del kit consultare la tavola ricambi allegata.

Symbols

The symbols used in this manual are aimed at making reading direct and easy. The symbols are used either to draw the reader's attention on potentially hazardous conditions, or to give practical advice or to supply general information. Pay the utmost attention to these symbols as they are used to remind of technical principles or safety measures which will not be repeated extensively. They must therefore be considered as "reminders". Check with this page in case of doubt about their meaning.



Warning

Failure to comply with these instructions may put you at risk and lead to severe injury or death.



Important

It indicates the possibility of damaging the motorcycle and/or its components if the instructions are not followed.



Notes

It supplies useful information about the operation in progress.

References

The parts highlighted in grey and with a reference number (e.g. ①) represent the accessory to be installed and any assembly components supplied with the kit.

The parts with alphabetic reference (e.g. Ⓐ) represent the original components present on the motorcycle.

All left and right indications are referred to the motorcycle direction of travel (forward riding position).

General notes



Warning

The operations listed in the following pages must be carried out by a specialised technician or by a Ducati authorised service centre.



Warning

Carefully perform the operations on the following pages since they might negatively affect rider safety.



Notes

The Workshop Manual of your motorcycle model is the documentation required to assemble the Kit.



Notes

Should it be necessary to change any kit parts, please refer to the attached spare part table.



Warning

Operating, servicing and maintaining a passenger vehicle or off-highway motor vehicle can expose you to chemicals including engine exhaust, carbon monoxide, phthalates, and lead, which are known to the State of California to cause cancer and birth defects or other reproductive harm. To minimize exposure, avoid breathing exhaust, do not idle the engine except as necessary, service your vehicle in a well-ventilated area and wear gloves or wash your hands frequently when servicing your vehicle. For more information go to www.P65Warnings.ca.gov/passenger-vehicle.

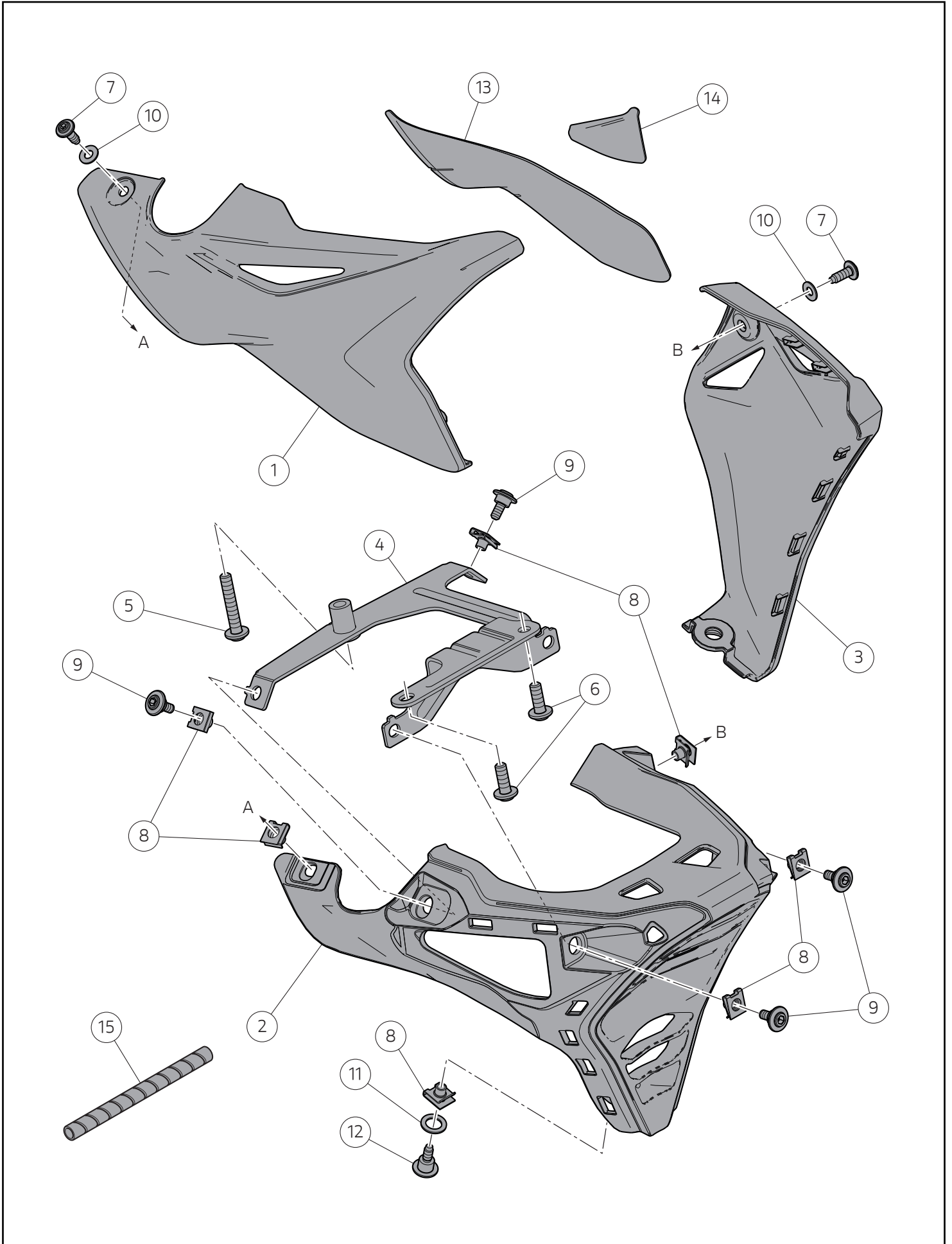

**Importante**

I componenti del kit possono essere soggetti ad aggiornamenti; consultare il DCS (Dealer Communication System) per avere informazioni sempre aggiornate.

**Important**

The parts of the kit can be updated; for information always up to date, please refer to DCS (Dealer Communication System).

Pos.	Denominazione	Name
1	Pannello destro	RH panel
2	Frontale puntale	Engine belly fairing front side
3	Pannello sinistro	LH panel
4	Staffa puntale	Engine belly fairing bracket
5	Vite TBEI M6x35	Screw TBEI M6x35
6	Vite TBEI M6x14	Screw TBEI M6x14
7	Vite speciale TBEI M5x12	TBEI special screw M5x12
8	Clip M5	M5 clip
9	Vite TCEIF M5x9	Screw TCEIF M5x9
10	Rosetta in nylon	Nylon washer
11	Rosetta in nylon	Nylon washer
12	Vite speciale TCEI M5x10.5	Special TCEI screw M5x10.5
13	Termoriflettente inferiore	Lower heat reflective element
14	Termoriflettente superiore	Upper heat reflective element
15	Guaina di protezione	Protection sheath

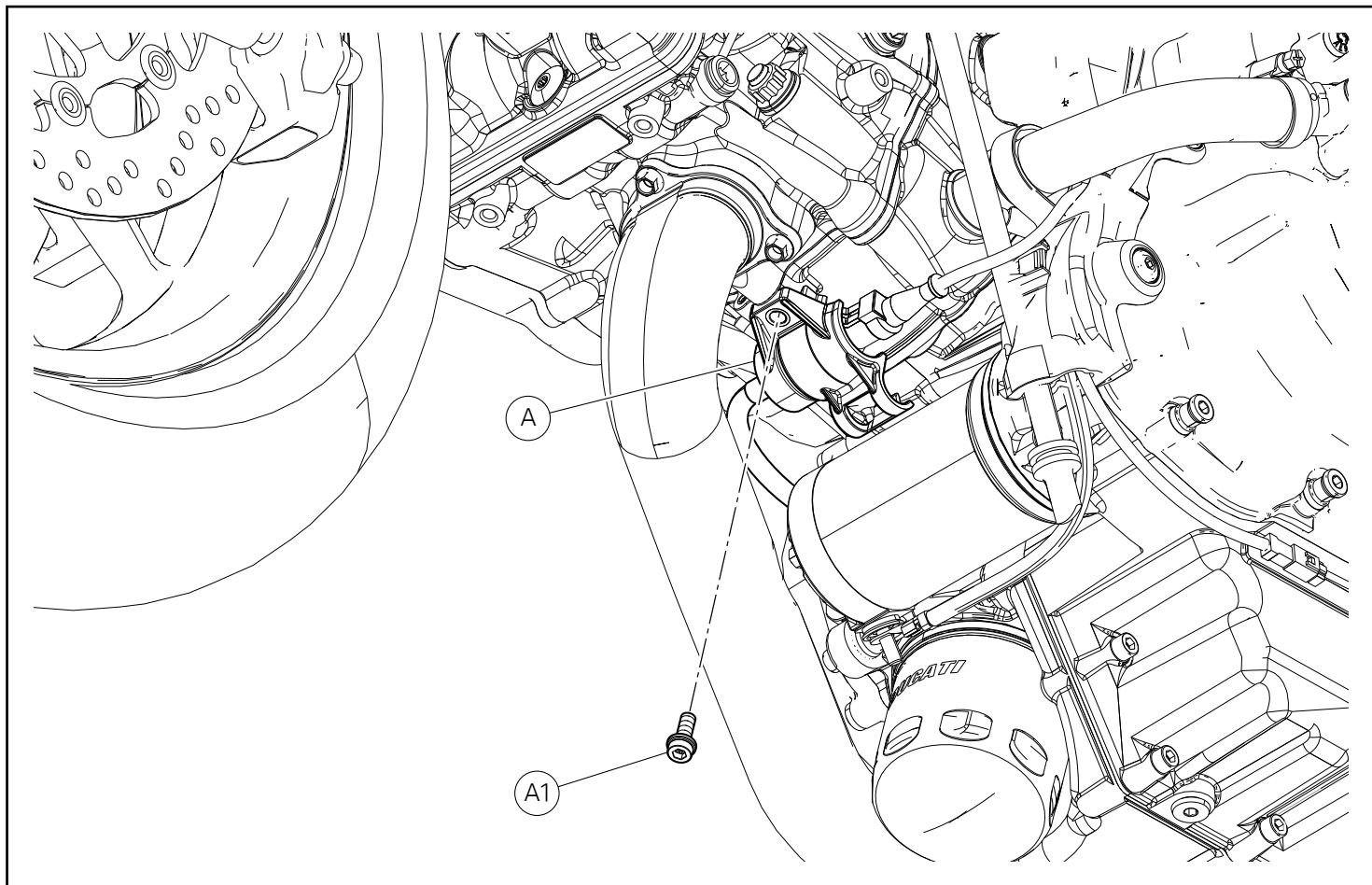

Smontaggio componenti originali

Smontaggio fissaggio supporto pressostato

Operando sul lato inferiore del motoveicolo, svitare e rimuovere la vite (A1) di fissaggio supporto pressostato (A).



Note

Pulire la madrevite, da eventuali residui di frenafili.

Removing the original components

Removing the pressure switch support fastener

Working on motorcycle lower side, loosen and remove screw (A1) fastening pressure switch support (A).



Notes

Clean the nut thread and remove any threadlocker residues.

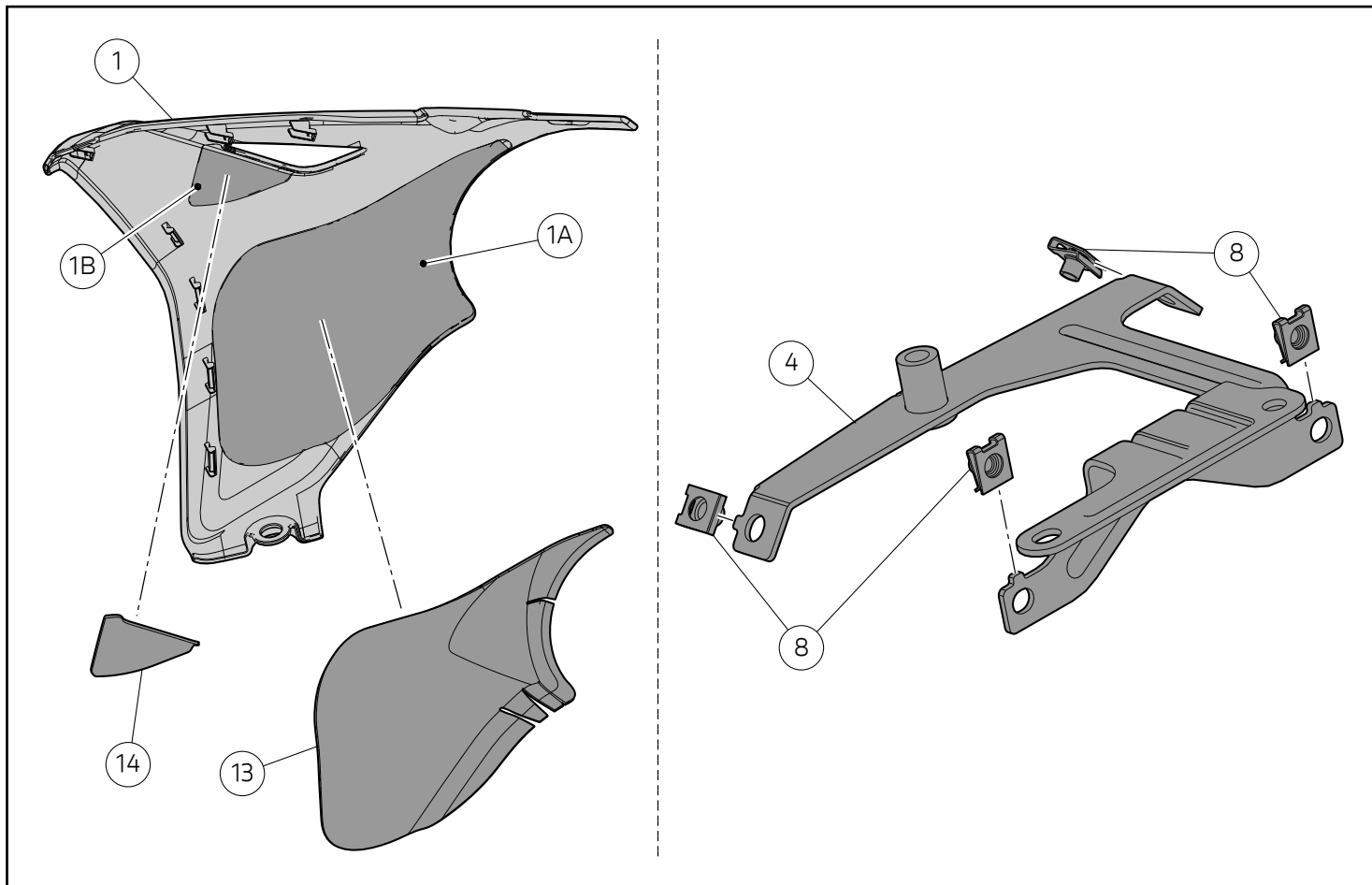

Montaggio componenti kit

● Importante

Verificare, prima del montaggio, che tutti i componenti risultino puliti e in perfetto stato. Adottare tutte le precauzioni necessarie per evitare di danneggiare qualsiasi parte nella quale ci si trova ad operare.

Premontaggio pannello destro

👁 Note

Per una corretta ed efficace adesione del termoriflettente inferiore (13) e del termoriflettente superiore (14), è necessario sgrassare le superfici interessate (1A) e (1B) del pannello destro (1).

Rimuovere la pellicola protettiva dal termoriflettente inferiore (13), prestando attenzione a non toccare con le dita la superficie adesiva. Applicare il termoriflettente (13) sulla superficie interna (1A) del pannello destro (1) precedentemente sgrassata.

Rimuovere la pellicola protettiva dal termoriflettente superiore (14), prestando attenzione a non toccare con le dita la superficie adesiva. Applicare il termoriflettente (14) sulla superficie interna (1B) del pannello destro (1) precedentemente sgrassata.

Premontaggio staffa puntale

Premontare n.4 clip (8) sulla staffa puntale (4), orientandole come mostrato in figura.

Assembling the kit components

● Important

Before assembling, check that all parts are clean and in good conditions. Adopt all necessary precautions to avoid damaging any part you are working on.

Pre-assembling the RH panel

👁 Notes

To make the lower heat reflective element (13) and the upper heat reflective element (14) correctly and effectively adhere, degrease the concerned surfaces (1A) and (1B) of RH panel (1).

Remove the protective film from the lower heat reflective element (13) and take care not to touch the adhesive surface with your fingers. Apply the heat reflective element (13) on the inner surface (1A) of RH panel (1) that you have previously degreased.

Remove the protective film from the upper heat reflective element (14) and take care not to touch the adhesive surface with your fingers. Apply the heat reflective element (14) on the inner surface (1B) of RH panel (1) that you have previously degreased.

Pre-assembling the engine belly fairing bracket

Pre-assemble no.4 clips (8) on engine belly fairing bracket (4), aiming them as shown in the figure.

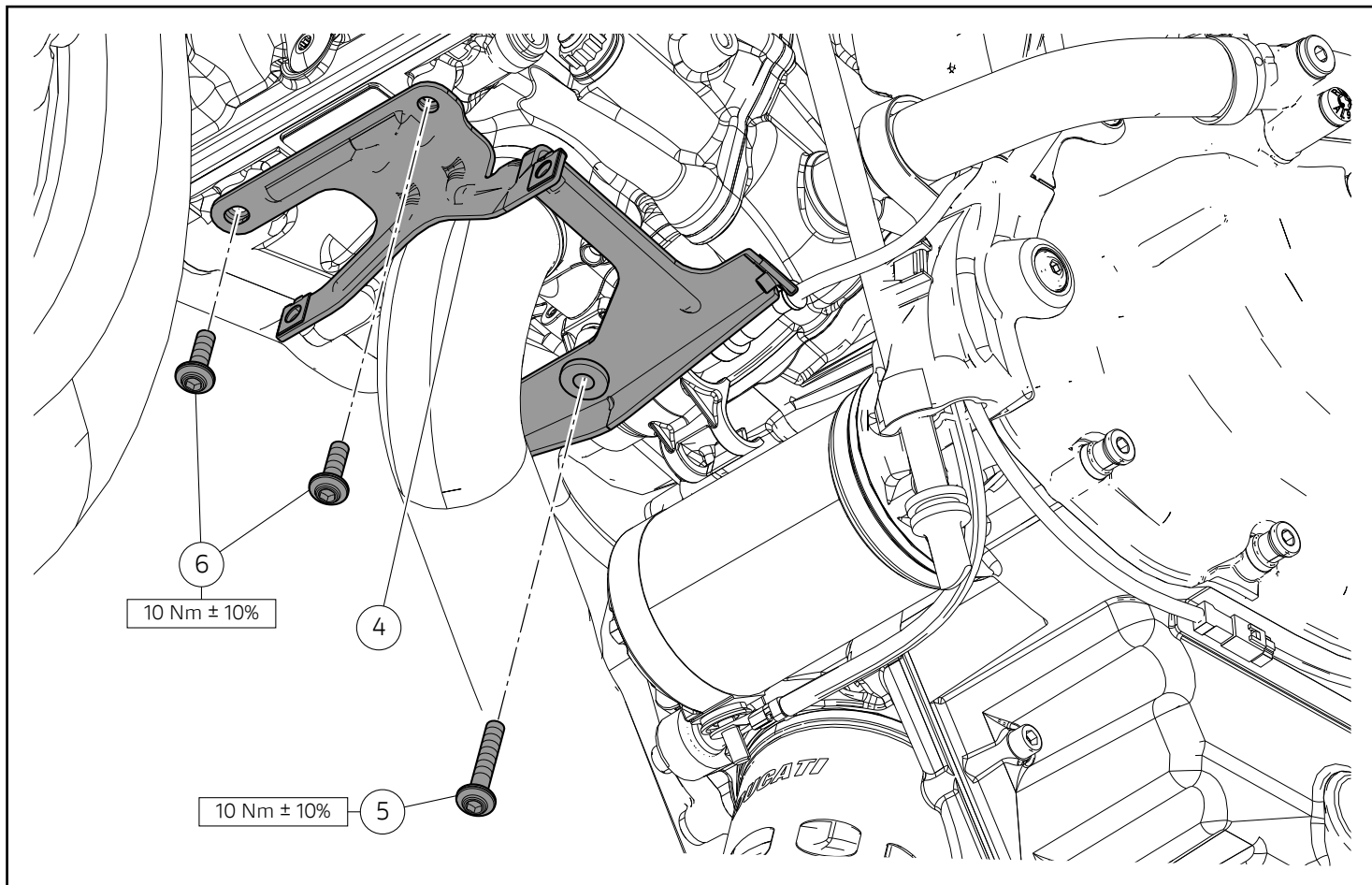

Montaggio staffa puntale

Operando sul lato inferiore del motoveicolo, posizionare la staffa puntale (4), orientandola come mostrato in figura. Impuntare la vite (5) e le n.2 viti (6). Serrare la vite (5) alla coppia indicata. Serrare le n.2 viti (6) alla coppia indicata.

Assembling the engine belly fairing bracket

Working on motorcycle lower side, position engine belly fairing bracket (4), aiming it as shown in the figure. Start screw (5) and no.2 screws (6). Tighten screw (5) to the specified torque. Tighten no.2 screws (6) to the specified torque.

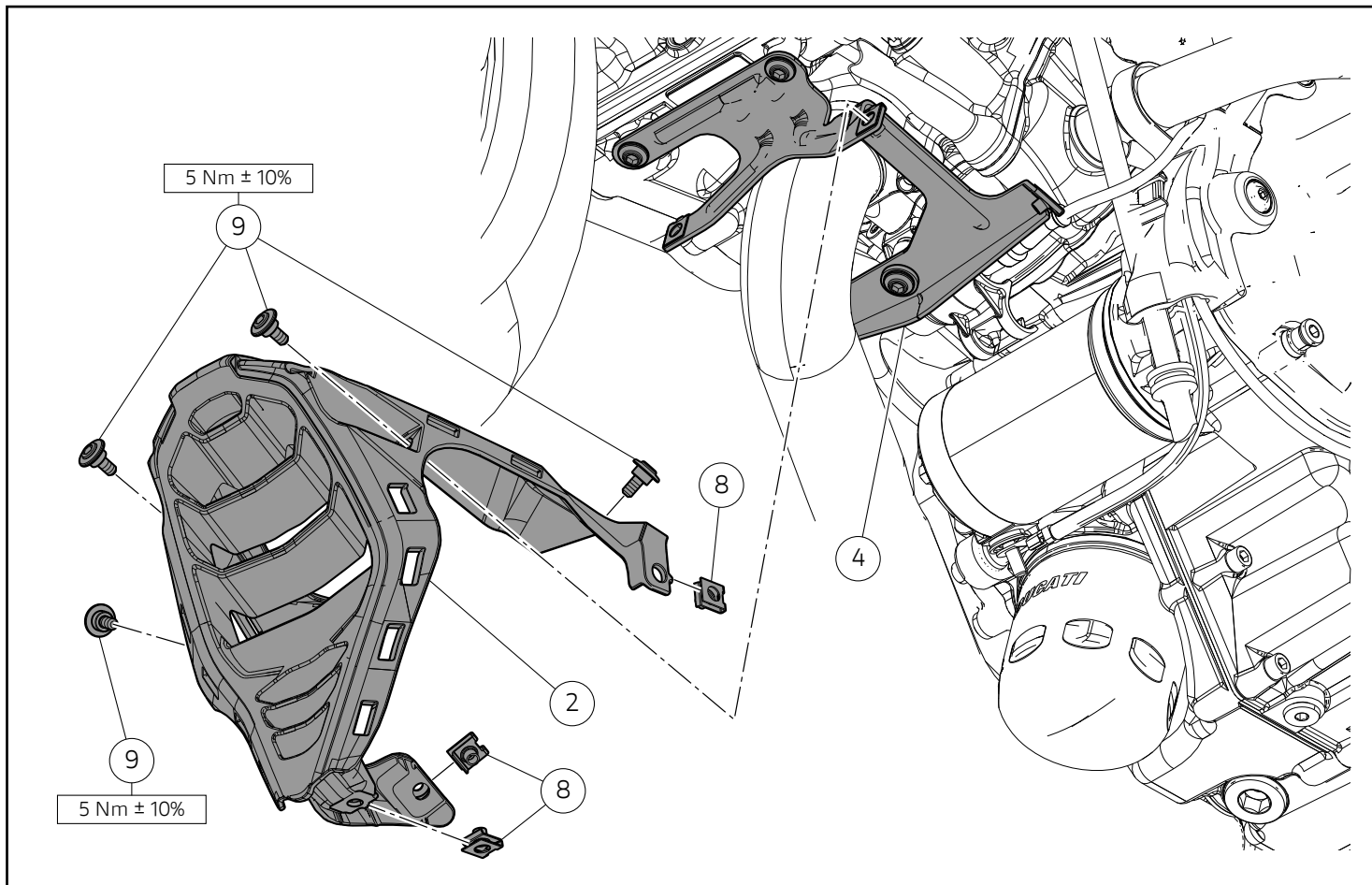

Montaggio frontale puntale

Montare le n.3 clip (8) sul frontale puntale (2), orientandole come mostrato in figura. Posizionare il frontale puntale (2) sulla staffa puntale (4) ed impuntare le n.4 viti (9). Serrare le n.4 viti (9) alla coppia indicata.

Assembling the engine belly fairing front part

Fit no.3 clips (8) on engine belly fairing front part (2), aiming them as shown in the figure. Position engine belly fairing front part (2) on engine belly fairing bracket (4) and start no.4 screws (9). Tighten no.4 screws (9) to the specified torque.

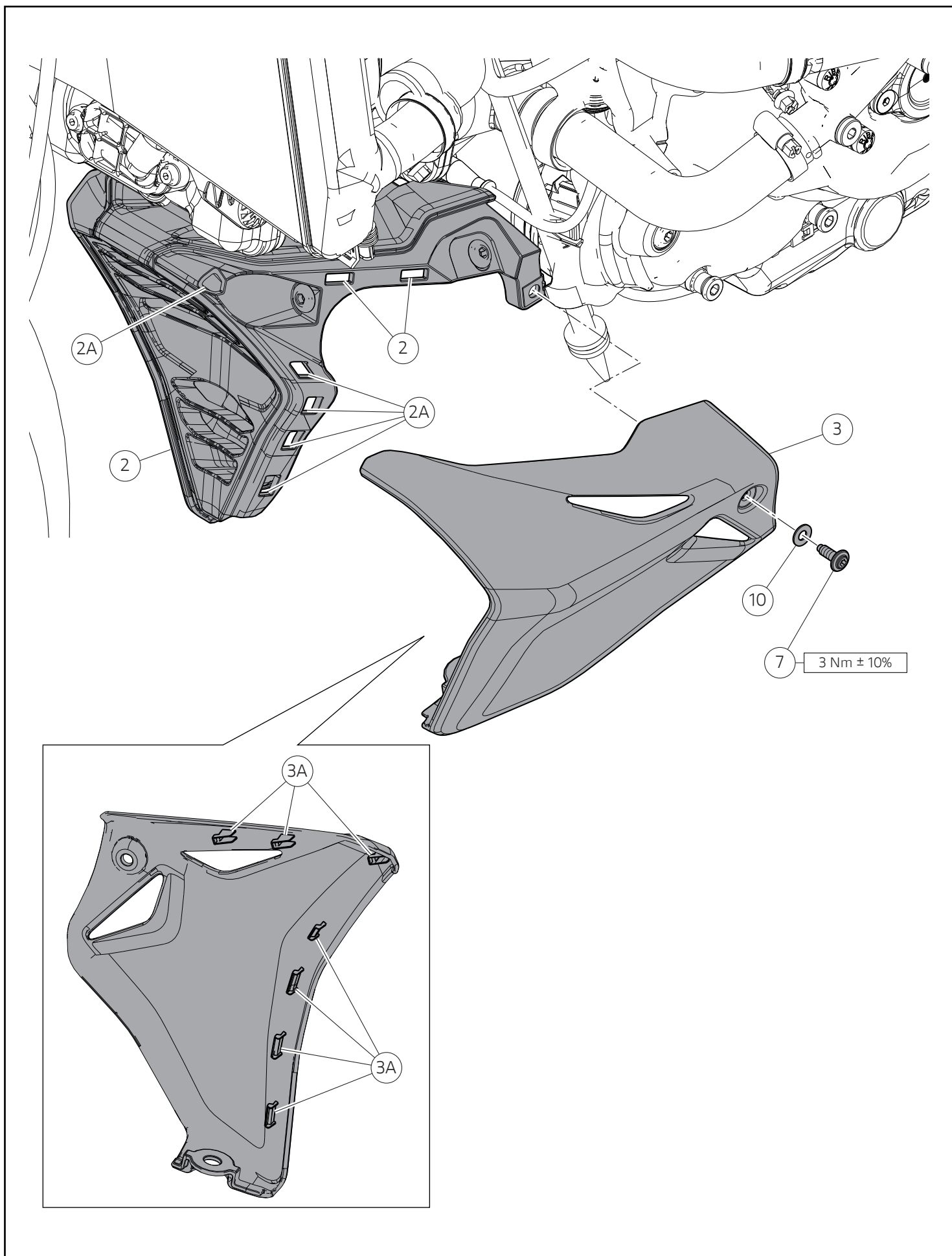

Montaggio pannello sinistro

Posizionare il pannello sinistro (3), sul puntale frontale (2), incastrando i dentini (3A) nelle relative sedi (2A). Inserire la rondella (10) sul filetto della vite (7) ed impuntare la vite (7). Serrare la vite (7) alla coppia indicata.

Assembling the LH panel

Position LH panel (3) on front engine belly fairing (2) by engaging teeth (3A) inside the relevant seats (2A). Fit washer (10) on the thread of screw (7) and start screw (7). Tighten screw (7) to the specified torque.

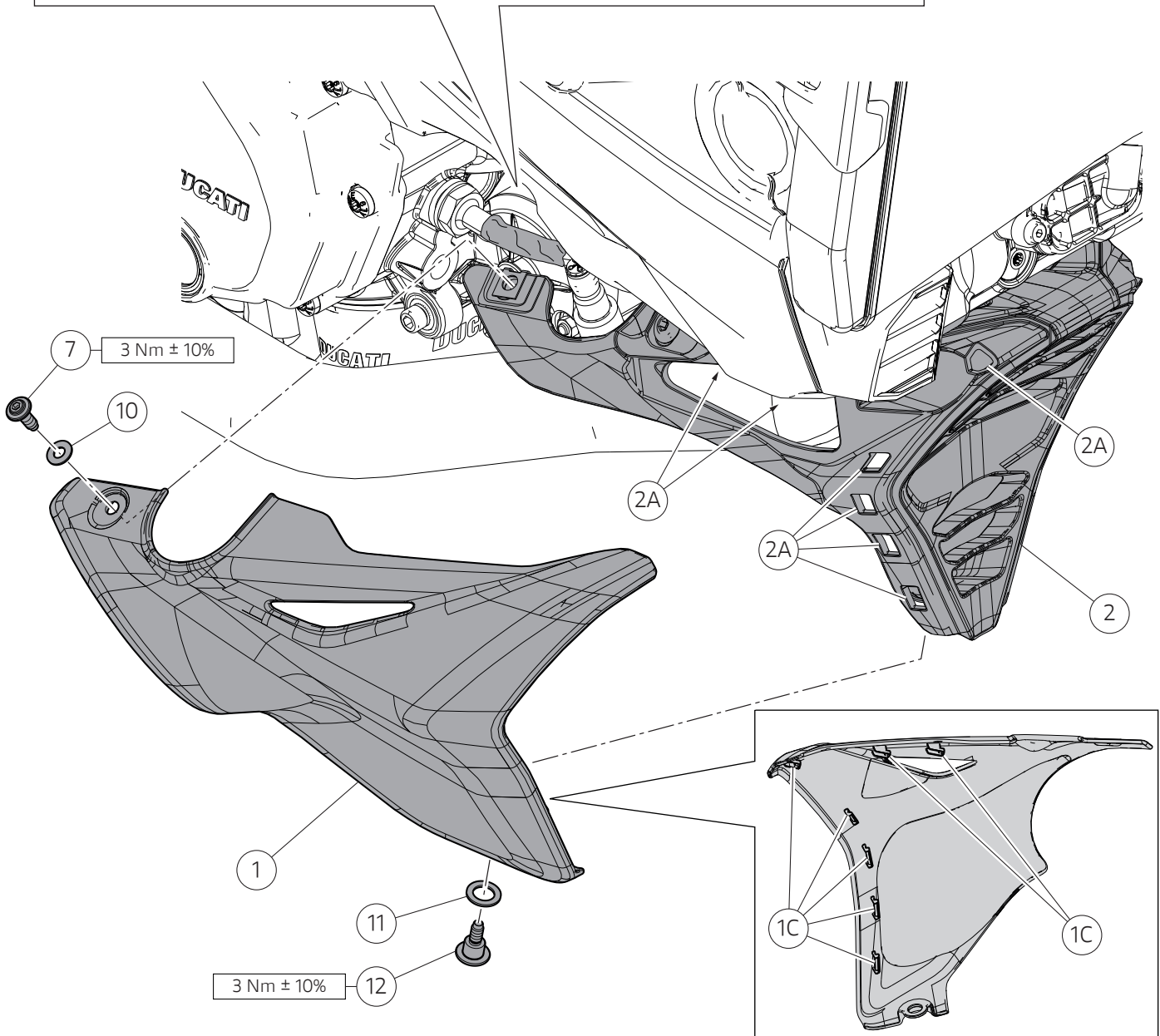
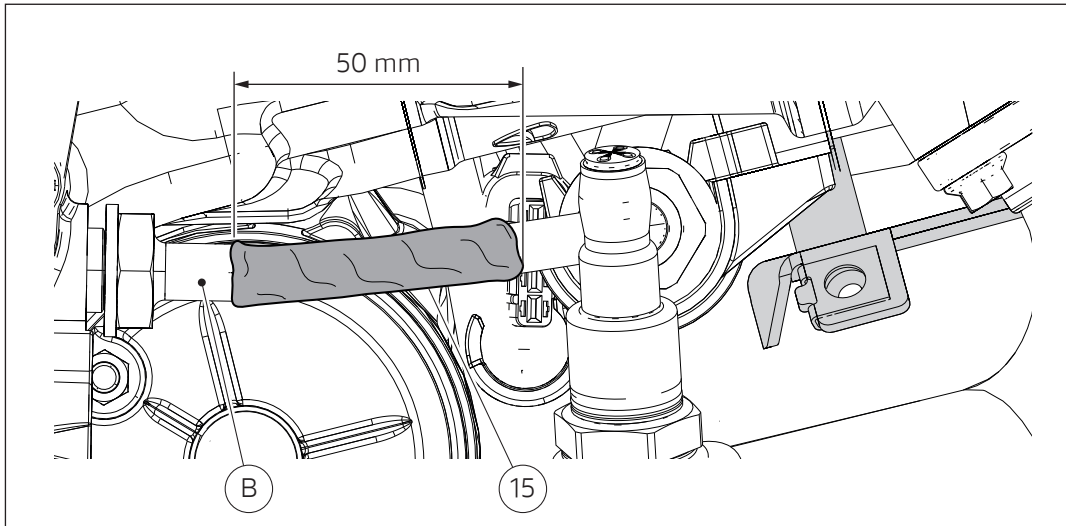

Montaggio pannello destro

Importante

Prima di montare il pannello destro (1), occorre posizionare la guaina di protezione (15) sul tubo pressostato (B).

Ricavare un pezzo di guaina di protezione (15) lungo 50 mm. Avvolgere attorno al tubo pressostato (B) il pezzo di guaina (15), come mostrato in figura, per evitare contatti con il pannello destro (1).

Posizionare il pannello destro (1), sul puntale frontale (2), incastrando i dentini (1C) nelle relative sedi (2A). Inserire la rondella (10) sul filetto della vite (7) ed impuntare la vite (7). Serrare la vite (7) alla coppia indicata.

Assembling the RH panel

Important

Before assembling the RH panel (1), position protective sheath (15) on pressure switch hose (B).

Take a protective sheath (15) section of 50 mm in length. Wrap the sheath section (15) around the pressure switch hose (B), as shown in the figure, in order to avoid contacts with the RH panel (1).

Position RH panel (1) on front engine belly fairing (2) by engaging teeth (1C) inside the relevant seats (2A). Fit washer (10) on the thread of screw (7) and start screw (7). Tighten screw (7) to the specified torque.

Kit puntale motore / Engine belly fairing kit / Kit support moteur / Kit Bugspoiler / Conjunto blindagem de proteção de motor / Kit tope motor / エンジンアンダーフェアリングキット - 97180961AA (Red) - 97180961AB (Black) - 97180961AC (Grey)

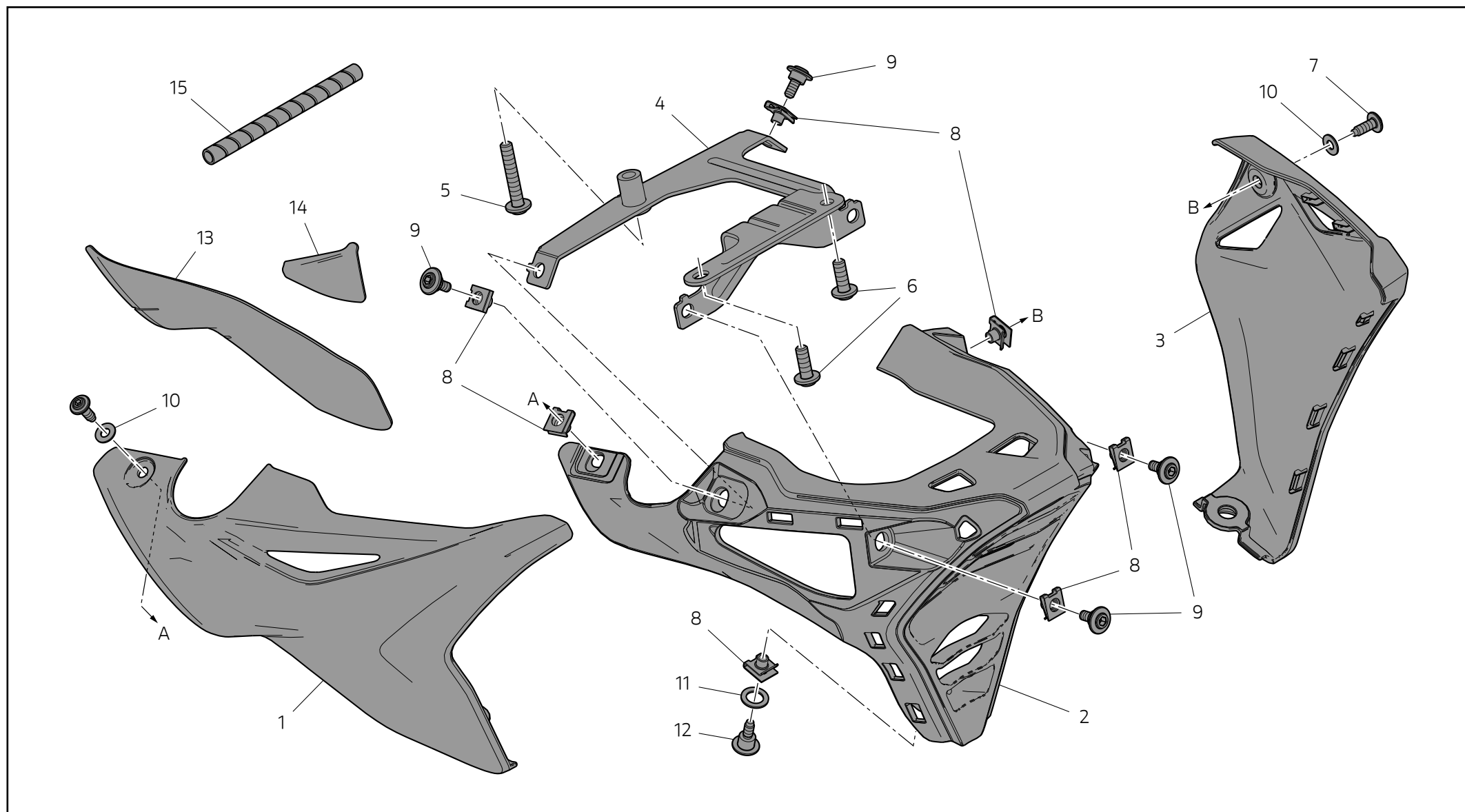

Pos.	Art.-Nr.	Denominazione	Name	Dénomination	Bezeichnung	Denominação	Denominación	名称	Q.ty
1	4801C351AA	Pannello destro (Rosso)	RH panel (Red)	Plaque droite (Rouge)	Rechtes Panel (Rot)	Painel direito (Vermelha)	Panel derecho (Roja)	右パネル (レッド)	1
1	4801C351AB	Pannello destro (Nero)	RH panel (Black)	Plaque droite (Noir)	Rechtes Panel (Schwarz)	Painel direito (Preta)	Panel derecho (Negra)	右パネル (ブラック)	1
1	4801C351AC	Pannello destro (Grigio)	RH panel (Grey)	Plaque droite (Gris)	Rechtes Panel (Grau)	Painel direito (Cinzenta)	Panel derecho (Gris)	右パネル (グレー)	1
2	4801C361A	Frontale puntale	Engine belly fairing front side	Face avant du support	Bugspoilerfront	Frente da blindagem de proteção	Tope frontal	フロントアンダーフェアリング	1
3	4801C371AA	Pannello sinistro (Rosso)	LH panel (Red)	Plaque gauche (Rouge)	Linkes Panel (Rot)	Painel esquerdo (Vermelha)	Panel izquierdo (Roja)	左パネル (レッド)	1
3	4801C371AB	Pannello sinistro (Nero)	LH panel (Black)	Plaque gauche (Noir)	Linkes Panel (Schwarz)	Painel esquerdo (Preta)	Panel izquierdo (Negra)	左パネル (ブラック)	1
3	4801C371AC	Pannello sinistro (Grigio)	LH panel (Grey)	Plaque gauche (Gris)	Linkes Panel (Grau)	Painel esquerdo (Cinzenta)	Panel izquierdo (Gris)	左パネル (グレー)	1
4	8301L371AA	Staffa puntale	Engine belly fairing bracket	Bride du support	Bugspoilerbügel	Braçadeira da blindagem de proteção	Sostén tope	アンダーフェアリングブラケット	1
5	77244403BA	Vite TBEI M6x35	Screw TBEI M6x35	Vis TBHC M6x35	Linsenkopfschraube mit Innensechskant M6x35	Parafuso de cabeça abaulada com sextavado interno M6x35	Tornillo TBEI M6x35	スクリュー TBEI M6x35	1
6	77210893B	Vite TBEI M6x14	Screw TBEI M6x14	Vis TBHC M6x14	Linsenkopfschraube mit Innensechskant M6x14	Parafuso de cabeça abaulada com sextavado interno M6x14	Tornillo TBEI M6x14	スクリュー TBEI M6x14	2
7	77211091C	Vite speciale TBEI M5x12	TBEI special screw M5x12	Vis spéciale TBHC M5x12	Spezial-Linsenschraube mit Innensechskant M5x12	Parafuso especial de cabeça abaulada com sextavado interno M5x12	Tornillo especial TBEI M5x12	専用スクリュー TBEI M5x12	2

Kit puntale motore / Engine belly fairing kit / Kit support moteur / Kit Bugspoiler / Conjunto blindagem de proteção de motor / Kit tope motor / エンジンアンダーフェアリングキット - 97180961AA (Red) - 97180961AB (Black) - 97180961AC (Grey)

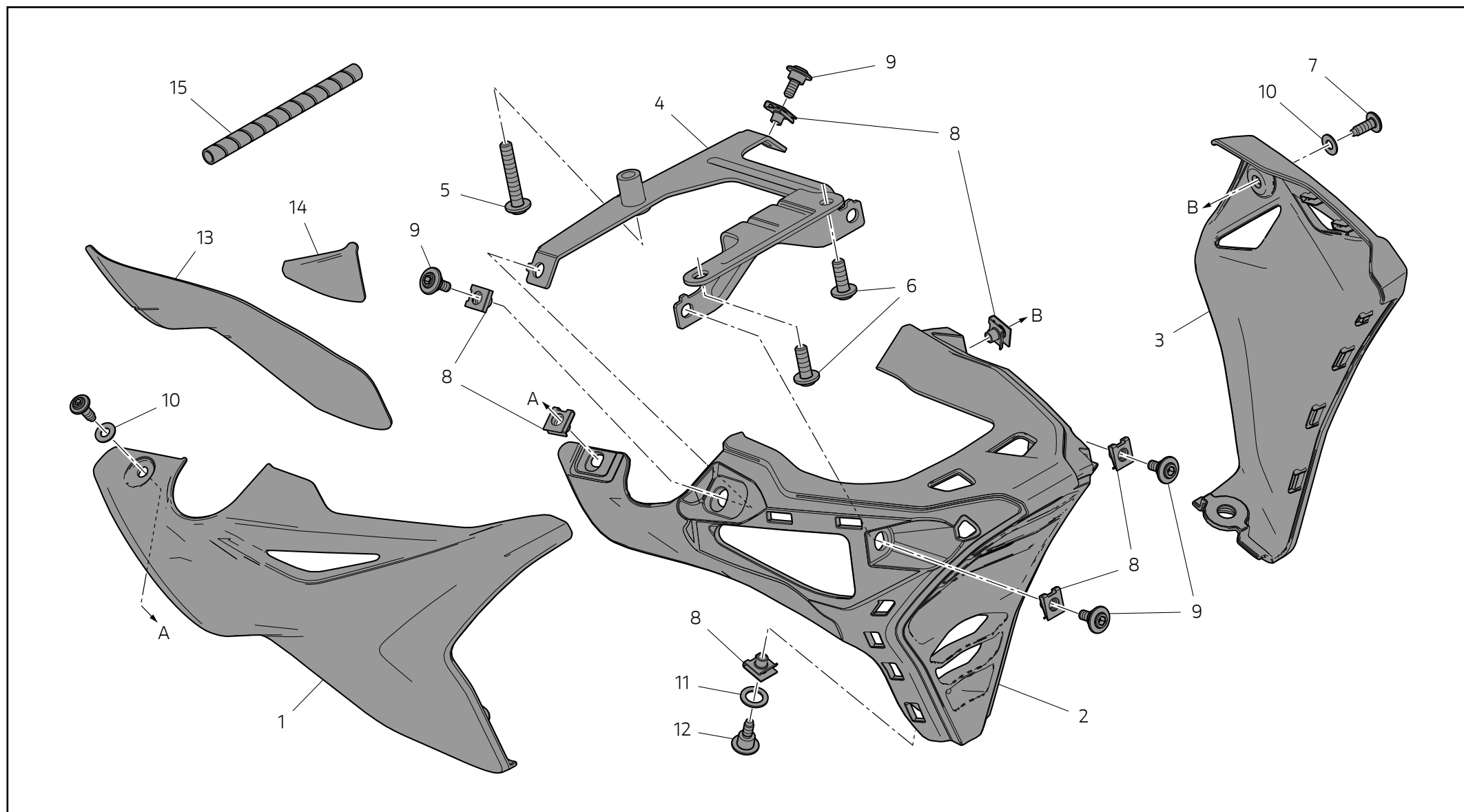

Pos.	Art.-Nr.	Denominazione	Name	Dénomination	Bezeichnung	Denominação	Denominación	名称	Q.ty
8	85041951AA	Clip M5	M5 clip	Clip M5	Klammer M5	Presilha M5	Clip M5	M5 クリップ	7
9	77214411BA	Vite TCEIF M5x9	Screw TCEIF M5x9	Vis TCHC M5x9	Zylinderschraube mit Innensechskant und Flansch M5x9	Parafuso de cabeça cilíndrica flangeada com sextavado interno M5x9	Tornillo TCEIF M5x9	スクリュー TCEIF M5x9	4
10	85611401A	Rosetta in nylon	Nylon washer	Rondelle en nylon	Nylon-Unterlegscheibe	Arruela de nylon	Arandela de nylon	ナイロンワッシャー	2
11	85212181A	Rosetta in nylon	Nylon washer	Rondelle en nylon	Nylon-Unterlegscheibe	Arruela de nylon	Arandela de nylon	ナイロンワッシャー	1
12	77210841C	Vite speciale TCEI M5x10.5	Special TCEI screw M5x10.5	Vis spéciale TCHC M5x10.5	Spezial-Innensechskantschraube M5x10.5	Parafuso especial de cabeça cilíndrica com sextavado interno M5x10.5	Tornillo especial TCEI M5x10.5	専用スクリュー TCEI M5x10.5	1
13	97410381A	Termoriflettente inferiore	Lower heat reflective element	Thermo-réfléchissant inférieur	Untere thermoreflektierende Folie	Termorrefletor inferior	Termo reflectante inferior	ロア断熱シート	1
14	97410391A	termoriflettente superiore	upper heat reflective element	Thermo-réfléchissant supérieur	Obere thermoreflektierende Folie	Termorrefletor superior	termo reflectante superior	アッパー断熱シート	1
15	4601F281A	Guaina di protezione	Protection sheath	Gaine de protection	Schutzummantelung	Bainha de proteção	Funda de protección	プロテクションシース	1